

Maintenance Manual

# VNA Master™

## Model MS2024B, MS2025B, MS2034B, MS2035B

Compact Handheld Vector Network Analyzer with Spectrum Analyzer

### MS2024B

VNA, 500 kHz to 4 GHz

### MS2025B

VNA, 500 kHz to 6 GHz

### MS2034B

VNA, 500 kHz to 4 GHz

SPA, 100 kHz to 4 GHz

### MS2035B

VNA, 500 kHz to 6 GHz

SPA, 100 kHz to 6 GHz

The Anritsu logo is located in the bottom right corner of the page. It features the word "Anritsu" in a bold, sans-serif font. The letter "A" is stylized with a diagonal slash through it.



## Safety Symbols

To prevent the risk of personal injury or loss related to equipment malfunction, Anritsu Company uses the following symbols to indicate safety-related information. For your own safety, please read the information carefully *before* operating the equipment.

### Symbols Used in Manuals

#### Danger



This indicates a very dangerous procedure that could result in serious injury or death, and possible loss related to equipment malfunction, if not performed properly.

#### Warning



This indicates a hazardous procedure that could result in light-to-severe injury or loss related to equipment malfunction, if proper precautions are not taken.

#### Caution



This indicates a hazardous procedure that could result in loss related to equipment malfunction if proper precautions are not taken.

### Safety Symbols Used on Equipment and in Manuals

The following safety symbols are used inside or on the equipment near operation locations to provide information about safety items and operation precautions. Ensure that you clearly understand the meanings of the symbols and take the necessary precautions *before* operating the equipment. Some or all of the following five symbols may or may not be used on all Anritsu equipment. In addition, there may be other labels attached to products that are not shown in the diagrams in this manual.



This indicates a prohibited operation. The prohibited operation is indicated symbolically in or near the barred circle.



This indicates a compulsory safety precaution. The required operation is indicated symbolically in or near the circle.



This indicates a warning or caution. The contents are indicated symbolically in or near the triangle.



This indicates a note. The contents are described in the box.



These indicate that the marked part should be recycled.

## For Safety

### Warning



Always refer to the operation manual when working near locations at which the alert mark, shown on the left, is attached. If the operation, etc., is performed without heeding the advice in the operation manual, there is a risk of personal injury. In addition, the equipment performance may be reduced.

Moreover, this alert mark is sometimes used with other marks and descriptions indicating other dangers.

### Warning

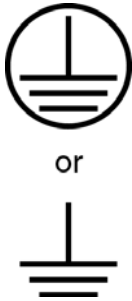

When supplying power to this equipment, connect the accessory 3-pin power cord to a 3-pin grounded power outlet. If a grounded 3-pin outlet is not available, use a conversion adapter and ground the green wire, or connect the frame ground on the rear panel of the equipment to ground. If power is supplied without grounding the equipment, there is a risk of receiving a severe or fatal electric shock.

### Warning



This equipment can not be repaired by the operator. Do not attempt to remove the equipment covers or to disassemble internal components. Only qualified service technicians with a knowledge of electrical fire and shock hazards should service this equipment. There are high-voltage parts in this equipment presenting a risk of severe injury or fatal electric shock to untrained personnel. In addition, there is a risk of damage to precision components.

### Caution



Electrostatic Discharge (ESD) can damage the highly sensitive circuits in the instrument. ESD is most likely to occur as test devices are being connected to, or disconnected from, the instrument's front and rear panel ports and connectors. You can protect the instrument and test devices by wearing a static-discharge wristband. Alternatively, you can ground yourself to discharge any static charge by touching the outer chassis of the grounded instrument before touching the instrument's front and rear panel ports and connectors. Avoid touching the test port center conductors unless you are properly grounded and have eliminated the possibility of static discharge.

Repair of damage that is found to be caused by electrostatic discharge is not covered under warranty.

# Table of Contents

---

## Chapter 1—General Information

1-2	Product Description	1-2
	Frequency Ranges	1-2
	Standard Accessories	1-2
1-3	Related Documents	1-3
1-4	Options	1-3
1-5	Anritsu Customer Service Centers	1-3
1-6	Recommended Test Equipment	1-4
	Vector Network Analyzer Test Equipment	1-4
	Spectrum Analyzer Test Equipment	1-5
	Instrument Options Test Equipment	1-6
1-7	Replaceable Parts and Assemblies	1-7
1-8	Performance Verification Procedures	1-9

## Chapter 2—VNA Performance Verification

2-2	Frequency Accuracy	2-1
	Equipment Required	2-1
	Procedure	2-1
2-3	Transmission Dynamic Range	2-2
	Equipment Required	2-2
	Procedure	2-2
2-4	Return Loss Measurement Accuracy Verification	2-3
	Equipment Required	2-3
	Procedure	2-3

## Chapter 3—Spectrum Analyzer Performance Verification

3-2	Residual Spurious Response	3-2
	Equipment Required	3-2
	Procedure	3-2
3-3	Displayed Average Noise Level (DANL)	3-4
	Equipment Required	3-4
	Procedure	3-4
3-4	Frequency Accuracy	3-6
	Equipment Required	3-6
	Related Tests	3-7
3-5	Single Side Band (SSB) Phase Noise	3-8
	Equipment Required	3-8
	Procedure	3-8
3-6	Spurious Response (Second Harmonic Distortion)	3-10
	Procedure	3-10

## Table of Contents (Continued)

---

3-7	Input Related Spurious (IRS) Signals	3-13
	Equipment Required	3-13
	Procedure	3-13
3-8	Resolution Bandwidth Accuracy	3-17
	Equipment Required	3-17
	Procedure	3-17
3-9	Amplitude Accuracy	3-20
	50 MHz Amplitude Accuracy Verification	3-20
	Equipment Required	3-20
	Procedure	3-20
	Amplitude Accuracy Across Frequency Verification	3-24
	Equipment Required	3-24
	Procedure	3-24
3-10	Third Order Intercept (TOI)	3-30
	Procedure	3-30

### Chapter 4—Options Performance Verification

4-2	VNA Mode Bias Tee (Option 10) Operational Check	4-2
	Equipment Required	4-2
	Procedure	4-2
4-3	GPS (Option 31) Operational Check	4-4
	Equipment Required	4-4
	Procedure	4-4
4-4	Spectrum Analyzer Frequency Accuracy with GPS On	4-6
	Equipment Required	4-6
	Procedure	4-6

### Chapter 5—Battery Information

5-1	Introduction	5-1
5-2	Battery Pack Removal and Replacement	5-2
	Battery Pack Information	5-4

### Chapter 6—Removal and Replacement

	Figures of Instrument Construction	6-1
	Removal And Replacement Instructions	6-2
6-2	Internal Anatomy of All Four VNA Master Models	6-3
	First Step for Opening the Case	6-3
	Screws on Case Back	6-4
	Basic Case Parts	6-5
	MS20xxB Instrument Overview	6-6
6-3	Internal Anatomy of MS202xB	6-7
	MS202xB Separating Case Back from Case Front	6-7
	MS202xB Parts in Case Front	6-8
	MS202xB Connector Panel	6-9

## Table of Contents (Continued)

---

6-4	Internal Anatomy of MS203xB	6-10
	MS203xB Separating Case Back from Case Front	6-10
	MS203xB Parts in Case Front	6-11
	MS203xB Connector Panel	6-12
6-5	Disassembly Sequence Overview	6-13
6-6	Opening the Instrument Case	6-14
6-7	PCB Assembly Replacement (MS202xB and MS203xB)	6-17
6-8	SPA Assembly Replacement	6-19
	PCB Assembly Out Of Case	6-20
	PCB Cable connections	6-22
6-9	GPS (Option 31) Replacement	6-24
6-10	Ethernet PCB Assembly (Option 411) Replacement	6-26
	Ethernet PCB Assembly	6-27
6-11	Main/VNA PCB Assembly Replacement	6-28
6-12	Main/VNA/DSP PCB Assembly Replacement	6-29
6-13	Fan Assembly Replacement	6-30
6-14	LCD Assembly Replacement	6-32
6-15	LCD Backlight PCB Removal and Replacement	6-35
6-16	Keypad and Keypad PCB Replacement	6-36
6-17	Touch Screen Replacement	6-37

### Chapter 7—Troubleshooting

7-2	Turn-on Problems	7-1
	Instrument Cannot Boot Up	7-1
	Instrument Cannot Complete Boot-Up	7-1
	Instrument Boots with No Display	7-2
	Boot-up Self Test Fails	7-2
7-3	Operating Problems	7-2
	Battery Pack Charging Problems	7-2
	Touch Screen Problems	7-2
	Vector Network Analyzer Problems	7-2
	Spectrum Analyzer Problems	7-3
	Option 10, VNA Bias Tee Problems	7-3
	Option 31, GPS Problems	7-3
7-4	Other Issues:	7-4

### Appendix A—Test Records

A-1	Introduction	A-1
A-2	MS2024B Test Record	A-2
	VNA Frequency Accuracy	A-2
	VNA Transmission Dynamic Range	A-2
	VNA Return Loss Measurements Accuracy	A-2

## Table of Contents (Continued)

---

A-3	MS2025B Test Record . . . . .	A-3
	VNA Frequency Accuracy . . . . .	A-3
	VNA Transmission Dynamic Range . . . . .	A-3
	VNA Return Loss Measurements Accuracy . . . . .	A-3
A-4	MS2034B Test Record . . . . .	A-4
	VNA Frequency Accuracy . . . . .	A-4
	VNA Transmission Dynamic Range . . . . .	A-4
	VNA Return Loss Measurements Accuracy . . . . .	A-4
	Spectrum Analyzer Residual Spurious Response . . . . .	A-4
	Spectrum Analyzer Displayed Average Noise Level (DANL) . . . . .	A-5
	Spectrum Analyzer Frequency Accuracy . . . . .	A-5
	Spectrum Analyzer Frequency Accuracy (Option 31, GPS) . . . . .	A-5
	Spectrum Analyzer Single Side Band (SSB) Phase Noise . . . . .	A-6
	Spectrum Analyzer Spurious Response (Second Harmonic Distortion) . . . . .	A-6
	Spectrum Analyzer Input Related Spurious (IRS) Signals . . . . .	A-6
	Spectrum Analyzer Resolution Bandwidth Accuracy . . . . .	A-7
	Spectrum Analyzer Amplitude Accuracy . . . . .	A-8
	Spectrum Analyzer Amplitude Accuracy (continued) . . . . .	A-9
	Spectrum Analyzer Amplitude Accuracy (continued) . . . . .	A-10
	Spectrum Analyzer Amplitude Accuracy (continued) . . . . .	A-11
	Spectrum Analyzer Amplitude Accuracy (continued) . . . . .	A-12
	Spectrum Analyzer Amplitude Accuracy (continued) . . . . .	A-13
	Third Order Intercept . . . . .	A-14
A-5	MS2035B Test Record . . . . .	A-15
	VNA Frequency Accuracy . . . . .	A-15
	VNA Transmission Dynamic Range . . . . .	A-15
	VNA Return Loss Measurements Accuracy . . . . .	A-15
	Spectrum Analyzer Residual Spurious Response . . . . .	A-16
	Spectrum Analyzer Displayed Average Noise Level (DANL) . . . . .	A-17
	Spectrum Analyzer Frequency Accuracy . . . . .	A-18
	Spectrum Analyzer Frequency Accuracy (Option 31, GPS) . . . . .	A-18
	Single Side Band (SSB) Phase Noise . . . . .	A-18
	Spectrum Analyzer Spurious Response (Second Harmonic Distortion) . . . . .	A-19
	Spectrum Analyzer Input Related Spurious (IRS) Signals . . . . .	A-19
	Spectrum Analyzer Resolution Bandwidth Accuracy . . . . .	A-20
	Spectrum Analyzer Amplitude Accuracy . . . . .	A-21
	Spectrum Analyzer Amplitude Accuracy (continued) . . . . .	A-22
	Spectrum Analyzer Amplitude Accuracy (continued) . . . . .	A-23
	Spectrum Analyzer Amplitude Accuracy (continued) . . . . .	A-24
	Spectrum Analyzer Amplitude Accuracy (continued) . . . . .	A-25
	Spectrum Analyzer Amplitude Accuracy (continued) . . . . .	A-26
	Spectrum Analyzer Amplitude Accuracy (continued) . . . . .	A-27
	Third Order Intercept . . . . .	A-28

### Appendix B—Test Fixture Schematics

B-2	T2904 Test Fixture Schematic . . . . .	B-1
B-3	T3377 Test Fixture Schematic . . . . .	B-2



---

B-4	T3536 Test Fixture Schematic .....	B-3
-----	------------------------------------	-----

**Index**



# Chapter 1 — General Information

## 1-1 Introduction

This manual provides maintenance instructions for Anritsu VNA Master Models MS2024B, MS2025B, MS2034B, and MS2035B. It provides a list of recommended test equipment, performance verification procedures, parts replacement procedures, and a replaceable parts list (Table 1-7 on page 1-8).

Appendix A contains blank test records, which should be copied before use. Familiarity with the basic operation of the front panel keys is assumed (for example, how to change measurement mode, how to preset the instrument, or the meaning of “soft key” (or “submenu key”). Before making any measurement, ensure that all equipment has warmed up for at least 30 minutes.

The information includes:

- Lists of required test equipment for performance verification:
  - Table 1-4, “Test Equipment Recommended for Vector Network Analyzer Verification” on page 1-4
  - Table 1-5, “Test Equipment Recommended for Spectrum Analyzer Verification” on page 1-5
  - Table 1-6, “Test Equipment Recommended for Options Verification” on page 1-6
- Replaceable Parts and Assemblies information:
  - Table 1-7, “List of Replaceable Parts” on page 1-8
- Performance Verification Procedures:
  - Table 1-8, “Required Performance Verification Procedures for Each Model of VNA Master MS20xxB” on page 1-9
  - Chapter 2, “VNA Performance Verification”
  - Chapter 3, “Spectrum Analyzer Performance Verification”
  - Chapter 4, “Options Performance Verification”
- Battery pack information (Chapter 5, “Battery Information”)
- Parts removal and replacement procedures (Chapter 6, “Removal and Replacement”)
- Troubleshooting information (Chapter 7, “Troubleshooting”)
- Blank test records (Appendix A, “Test Records”)

**Note**

Anritsu recommends that you make a copy of the blank test records to document the measurements each time a Performance Verification is performed. Continuing to document this process each time it is performed provides a detailed history of instrument performance, which allows you to observe trends.

Throughout this manual, the following terms apply:

- VNA Master or MS20xxB refers to the MS2024B, MS2025B, MS2034B, or MS2035B
- MS202xB refers to either the MS2024B or the MS2025B
- MS203xB refers to either the MS2034B or the MS2035B

Familiarity with the basic operation of the front panel keys (for example, how to change measurement mode, preset the unit, or the meaning of submenu button (Soft Key), or main menu button (Hard Key) is assumed. Refer to the VNA Master MS20xxB User Guide (Anritsu part number 10580-00301).

## 1-2 Product Description

The MS202xB VNA Master is a portable handheld vector network analyzer featuring precise performance and essential RF capabilities. It is designed to conduct accurate vector-corrected 1-port magnitude, phase, and fault location measurements and 2-port magnitude, phase, group delay measurements from 500 kHz to 6 GHz.

The MS203xB VNA Master is a portable handheld instrument with integrated vector network analysis and spectrum analysis capabilities in a single instrument. It offers the same vector network analysis capability as the MS202xB VNA Master as well as spectrum analysis capability that provides quick and accurate measurement results for monitoring, measuring, and analyzing signal environments. The spectrum analyzer offers board spectrum analysis with frequency coverage to 6 GHz, impressive dynamic range, and excellent phase noise performance. Standard measurements include field strength, occupied bandwidth (OBW), channel power, adjacent channel power ratio (ACPR), and carrier to interference (C/I) ratio.

### Frequency Ranges

**Table 1-1.** Frequency Ranges

Instrument	Frequency Range
MS2024B	VNA, 500 kHz to 4 GHz, N Connectors
MS2025B	VNA, 500 kHz to 6 GHz, N Connectors
MS2034B	VNA, 500 kHz to 4 GHz, N Connectors SPA, 100 kHz to 4 GHz, N Connectors
MS2035B	VNA, 500 kHz to 6 GHz, N Connectors SPA, 100 kHz to 6 GHz, N Connectors

### Standard Accessories

**Table 1-2.** Standard Accessories

Anritsu Part Number	Accessory
10580-00301	MS20xxB User Guide
2300-498	Master Software Tools CD ROM
633-44	Rechargeable battery, Li-Ion
40-168-R	AC – DC Adapter
806-141-R	Automotive 12 Volt DC Adapter
3-2000-1498	USB A-mini B Cable, 3 meters (10 feet)
3-68736	Soft Carrying Case

## 1-3 Related Documents

Other documents are available for the MS20xxB at the Anritsu Web site:

[www.anritsu.com](http://www.anritsu.com)

VNA Master MS20xxB User Guide – part number 10580-00301

VNA Master MS20xxB Programming Manual – part number 10580-00302

VNA Master MS20xxB Technical Data Sheet – part number 11410-00549

Vector Network Analyzer Measurement Guide – part number 10580-00289

Spectrum Analyzer Measurement Guide – part number 10580-00231

## 1-4 Options

**Table 1-3.** Instrument Options

Option	Description
10	Built-in Variable Bias-Tee (+12 to +32 V in 0.1 V steps)
15	Vector Voltmeter
19	High Accuracy Power Meter (requires external USB Power Sensor)
25	Interference Analysis (MS203XB Only)
27	Channel Scanner (MS203XB Only)
31	GPS Receiver (Requires GPS antenna 2000-1528-R sold separately)
411	Ethernet Port
431	Coverage Mapping (MS203XB Only), Requires GPS
501	Distance Domain
509	AM/FM/PM Demodulation Analyzer (MS203XB Only)

## 1-5 Anritsu Customer Service Centers

For the latest service and sales information in your area, please visit the following URL:

<http://www.anritsu.com/contact.asp>

Choose a country for regional contact information.

## 1-6 Recommended Test Equipment

The following test equipment is recommended for use in testing and maintaining Anritsu VNA Master Models MS2024B, MS2025B, MS2034B, and MS2035B. [Table 1-4 on page 1-4](#) is a list of test equipment that is recommended for verifying the vector network analyzer functions and associated VNA options. [Table 1-5 on page 1-5](#) is a list of test equipment that is recommended for verifying the spectrum analyzer functions and associated SPA options. [Table 1-6 on page 1-6](#) is a list of test equipment that is recommended for verifying the functions of installed options.

### Vector Network Analyzer Test Equipment

**Table 1-4.** Test Equipment Recommended for Vector Network Analyzer Verification

Instrument	Critical Specification	Recommended Manufacturer/Model
Frequency Counter	Frequency: 2 to 3 GHz	Anritsu Model MF2412C
Frequency Reference	Frequency: 10 MHz	Symmetricom RubiSource T&M
Open/Short/Load	Frequency: DC to 6 GHz Connector: N(m)	Anritsu Model OSLN50-1
Open/Short/Load	Frequency: DC to 6 GHz Connector: N(f)	Anritsu Model OSLNF50-1
RF Coaxial Cable	Frequency: DC to 18 GHz Impedance: 50 ohm Connector: N(m) to N(m)	Anritsu Model 15NN50-1.0B
6 dB Offset Termination	Frequency: DC to 6 GHz Connector: N(m)	Anritsu Model SC7424
20 dB Offset Termination	Frequency: DC to 6 GHz Connector: K(m)	Anritsu Model SC7423
Coaxial Cable	Connector: BNC(m) to BNC(m) Impedance: 50 ohm	Anritsu 2000-1627-R
Interface Cable	USB A to USB mini	Anritsu 3-2000-1498
Test Software		Anritsu 2300-535
PC Controller	Microsoft Windows XP, 1 GB RAM, at least 20 MB free hard disk space, USB 2.0 Type A port with National Instruments VISA <sup>a</sup> Version 3.6 or later loaded	Any

a.National Instrument VISA license is available from National Instruments as a stand-alone software package or as part of National Instruments GPIB adapter hardware package. Please contact National Instruments for details.

## Spectrum Analyzer Test Equipment

**Table 1-5.** Test Equipment Recommended for Spectrum Analyzer Verification

Instrument	Critical Specification	Recommended Manufacturer/Model
Frequency Reference	Frequency: 10 MHz	Symmetricon RubiSource T&M
Synthesized Signal Generator	Frequency: 0.1 Hz to 20 GHz, Power Output: +16 dBm, Step attenuator installed	Anritsu Model MG3692B or MG3692C with Options 2A, 4, and 22 (Quantity 2)
Power Meter	Power Range: -70 to +20 dBm	Anritsu Model ML2438A
Power Sensor	Frequency: 100 kHz to 18 GHz Power Range: -30 to +20 dB	Anritsu Model SC7400 (Quantity 2)
Power Sensor	Frequency: 100 kHz to 18 GHz Power Range: -67 to +20 dB	Anritsu Model MA2442D
Adapter	Frequency: DC to 18 GHz N(m)-N(m), 50 Ohm	Anritsu Model 34NN50A
Adapter	Frequency: DC to 18 GHz RK(m)-N(f), 50 Ohm	Anritsu Model 34RKNF50
RF Coaxial Cable	Frequency: DC to 18 GHz Impedance: 50 ohm Connector: N(m)-N(m)	Anritsu Model 15NN50-1.5C (Quantity 2)
Coaxial Cable	Impedance: 50 ohm Connector: BNC(m) to BNC(m)	Anritsu 2000-1627-R (Quantity 3)
50 Ohm Termination	Frequency: DC to 18 GHz Impedance: 50 ohm Connector: N(m)	Anritsu Model 28N50-2
Power Splitter	Frequency: DC to 18 GHz Connector: N(f)	Aeroflex/Weinschel Model 1870A
Fixed Attenuator	Frequency: DC to 18 GHz 2 dB Attenuation	Aeroflex/Weinschel Model 44-2 (Quantity 2)
Fixed Attenuator	Frequency: DC to 18 GHz 6 dB Attenuation	Aeroflex/Weinschel Model 44-6 (Quantity 2)
Fixed Attenuator	Frequency: DC to 18 GHz 10 dB Attenuation	Aeroflex/Weinschel Model 44-10 (Quantity 2)
Fixed Attenuator	Frequency: DC to 18 GHz 20 dB Attenuation	Aeroflex/Weinschel Model 44-20 (Quantity 2)
Tee Adapter	Frequency: 10 MHz Impedance: 50 ohm Connector: BNC(m) to BNC(f)/BNC(f)	Anritsu 3-2600-2 (Quantity 2)

## Instrument Options Test Equipment

**Table 1-6.** Test Equipment Recommended for Options Verification

Instrument	Critical Specification	Recommended Manufacturer/Model
Load Test Fixture (for Option 10)	Resistance: 40 ohm Power: 5 watt	Anritsu Model T2904
Load Test Fixture (for Option 10)	Resistance: 105 ohm Power: 1 watt	Anritsu Model T3377
Load Test Fixture (for Option 10)	Resistance: 78 ohm Power: 20 watt	Anritsu Model T3536
GPS Antenna (for Option 31)	Magnet Mount (active 3 to 5V) with SMA connector	Anritsu 2000-1528-R
Adapter (for Option 31)	Connector: SMA(m) to BNC(f)	Pomona part number 4290
Terminator (for Option 31)	Connector: BNC(m) Impedance: 93 ohm	Amphenol part number B1004A-ND3G-93R-0.05-1W



## 1-7 Replaceable Parts and Assemblies

To ensure that the correct options are provided on the replacement assembly when ordering either a VNA Module Assembly or Main PCB Assembly, all installed instrument options must be declared on the order.

The installed options are listed on a label on the top of the VNA Master. They can also be viewed in the System Status display. The example Status display that is shown in [Figure 1-1](#) may not be the same as the Status display of your instrument.

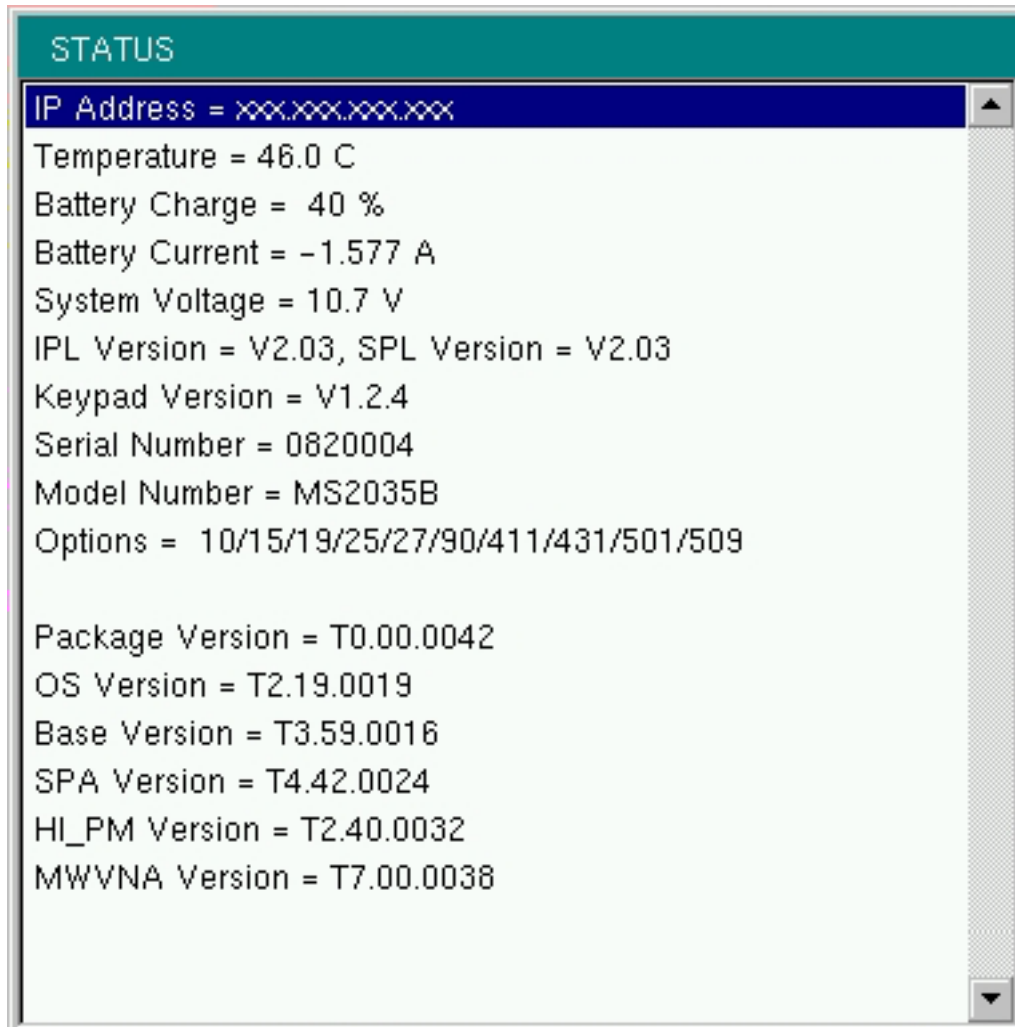

**Figure 1-1.** Status Display from System Menu (example)

Table 1-7 summarizes the available replaceable parts and assemblies.

**Table 1-7.** List of Replaceable Parts

Part Number	Description
ND72051	Main/VNA PCB Assembly for MS2024B instruments – Does not include GPS Receiver Module – Does not include Ethernet Option PCB Assembly
ND72052	Main/VNA PCB Assembly for MS2025B instruments – Does not include GPS Receiver Module – Does not include Ethernet Option PCB Assembly
ND72117	Main/VNA/DSP PCB Assembly for MS2034B instruments – Does not include SPA PCB Assembly – Does not include GPS Receiver Module – Does not include Ethernet Option PCB Assembly
ND72118	Main/VNA/DSP PCB Assembly for MS2035B instruments – Does not include SPA PCB Assembly – Does not include GPS Receiver Module – Does not include Ethernet Option PCB Assembly
ND72119	SPA PCB Assembly for MS2034B and MS2035B instruments
ND70320	GPS Receiver Module, Option 31 – Does not include GPS antenna, 2000-1528-R
ND72101	Ethernet Option PCB Assembly, Option 411
3-15-147	LCD Display
3-68567-3	LCD Backlight Inverter PCB Assembly
3-72811-3	Main Numeric Keypad PCB Assembly
3-72773	Rubber Keypad
3-410-103	Rotary Encoder – Does not include the Rotary Knob, 3-61360-2
3-61360-2	Encoder Rotary Knob – Does not include Rotary Encoder, 3-410-103
3-72779	Fan Assembly
ND73192	Speaker
ND73867*	Touch Screen with Gasket * Firmware version 1.05 or later must be installed when using this part.
ND73191	Top Case with Gasket – Does not include LCD, touch screen, encoder, and keypad assemblies
ND73199	Bottom Case – Does not include Tilt Bail
ND73200	Tilt Bail
3-70737	Model ID Label for MS2024B instruments
3-70738	Model ID Label for MS2025B instruments
3-70739	Model ID Label for MS2034B instruments
3-70750	Model ID Label for MS2035B instruments
ND73201	Battery Door
633-44	Rechargeable Battery, Lithium-Ion
40-168-R	AC to DC Power Adapter (for all MS202xB and MS203xB instruments)
3-68736	Soft Carrying Case
806-141-R	Automotive 12 Volt DC Adapter (for all MS202xB and MS203xB instruments)
3-2000-1498	USB Type 2 A to Mini B Cable, 3 meters (10 feet) (for all MS202xB and MS203xB instruments)

## 1-8 Performance Verification Procedures

Performance verification procedures are in the following Chapters:

- [Chapter 2, “VNA Performance Verification”](#)
- [Chapter 3, “Spectrum Analyzer Performance Verification”](#)
- [Chapter 4, “Options Performance Verification”](#)

Refer to [Table 1-8](#) for the list of performance verification procedures that are required for each model. Perform all of the procedures that have an “X” in the Std column. Also perform the procedures with a “X” in the Opt 10 and Opt 31 columns when these options are installed in the VNA Master.

**Table 1-8.** Required Performance Verification Procedures for Each Model of VNA Master MS20xxB

Model	Performance Verification Procedure	Std	Opt 10	Opt 31	Procedure in
MS2024B	VNA Frequency Accuracy	X			<a href="#">Chapter 2</a>
	VNA Transmission Dynamic Range	X			<a href="#">Chapter 2</a>
	VNA Return Loss Measurements Accuracy	X			<a href="#">Chapter 2</a>
	VNA Mode Bias Tee Operational Check		X		<a href="#">Chapter 4</a>
	GPS Operational Check			X	<a href="#">Chapter 4</a>
MS2025B	VNA Frequency Accuracy	X			<a href="#">Chapter 2</a>
	VNA Transmission Dynamic Range	X			<a href="#">Chapter 2</a>
	VNA Return Loss Measurements Accuracy	X			<a href="#">Chapter 2</a>
	VNA Mode Bias Tee Operational Check		X		<a href="#">Chapter 4</a>
	GPS Operational Check			X	<a href="#">Chapter 4</a>
MS2034B	VNA Frequency Accuracy	X			<a href="#">Chapter 2</a>
	VNA Transmission Dynamic Range	X			<a href="#">Chapter 2</a>
	VNA Return Loss Measurements Accuracy	X			<a href="#">Chapter 2</a>
	VNA Mode Bias Tee Operational Check		X		<a href="#">Chapter 4</a>
	GPS Operational Check			X	<a href="#">Chapter 4</a>
	Spectrum Analyzer Residual Spurious Response	X			<a href="#">Chapter 3</a>
	Spectrum Analyzer Displayed Average Noise Level (DANL)	X			<a href="#">Chapter 3</a>
	Spectrum Analyzer Frequency Accuracy	X			<a href="#">Chapter 3</a>
	Spectrum Analyzer Frequency Accuracy with GPS On			X	<a href="#">Chapter 4</a>
	Spectrum Analyzer Single Side Band (SSB) Phase Noise	X			<a href="#">Chapter 3</a>
	Spectrum Analyzer Spurious Response (Second Harmonic Distortion)	X			<a href="#">Chapter 3</a>
	Spectrum Analyzer Input Related Spurious (IRS) Signals	X			<a href="#">Chapter 3</a>
	Spectrum Analyzer Resolution Bandwidth (RBW) Accuracy	X			<a href="#">Chapter 3</a>
	Spectrum Analyzer Amplitude Accuracy	X			<a href="#">Chapter 3</a>
Spectrum Analyzer Third Order Intercept (TOI)	X			<a href="#">Chapter 3</a>	

**Table 1-8.** Required Performance Verification Procedures for Each Model of VNA Master MS20xxB

Model	Performance Verification Procedure	Std	Opt 10	Opt 31	Procedure in
MS2035B	VNA Frequency Accuracy	X			<a href="#">Chapter 2</a>
	VNA Transmission Dynamic Range	X			<a href="#">Chapter 2</a>
	VNA Return Loss Measurements Accuracy	X			<a href="#">Chapter 2</a>
	VNA Mode Bias Tee Operational Check		X		<a href="#">Chapter 4</a>
	GPS Operational Check			X	<a href="#">Chapter 4</a>
	Spectrum Analyzer Residual Spurious Response	X			<a href="#">Chapter 3</a>
	Spectrum Analyzer Displayed Average Noise Level (DANL)	X			<a href="#">Chapter 3</a>
	Spectrum Analyzer Frequency Accuracy	X			<a href="#">Chapter 3</a>
	Spectrum Analyzer Frequency Accuracy with GPS On			X	<a href="#">Chapter 4</a>
	Spectrum Analyzer Single Side Band (SSB) Phase Noise	X			<a href="#">Chapter 3</a>
	Spectrum Analyzer Spurious Response (Second Harmonic Distortion)	X			<a href="#">Chapter 3</a>
	Spectrum Analyzer Input Related Spurious (IRS) Signals	X			<a href="#">Chapter 3</a>
	Spectrum Analyzer Resolution Bandwidth Accuracy	X			<a href="#">Chapter 3</a>
	Spectrum Analyzer Amplitude Accuracy	X			<a href="#">Chapter 3</a>
	Spectrum Analyzer Third Order Intercept (TOI)	X			<a href="#">Chapter 3</a>

# Chapter 2 — VNA Performance Verification

## 2-1 Introduction

This chapter contains tests that are used to verify the Vector Network Analyzer performance of VNA Master Models MS2024B, MS2025B, MS2034B, and MS2035B. Blank performance verification test records are provided in [Appendix A](#). Make copies of the blank test records and use them to record measured values.

The vector network analyzer performance verification tests are as follows:

- “Frequency Accuracy” on page 2-1
- “Transmission Dynamic Range” on page 2-2
- “Return Loss Measurement Accuracy Verification” on page 2-3

<b>Caution</b> Verify that all equipment has warmed up for at least 30 minutes before making any measurements.
--

## 2-2 Frequency Accuracy

The following test can be used to verify the CW frequency accuracy of the vector network analyzer of the VNA Master. Measurement calibration is not required for this test.

### Equipment Required

- Frequency Counter, Anritsu Model MF2412C
- 10 MHz Time Base Reference
- RF Coaxial Cable, Anritsu Model 15NN50-1.0B
- BNC male to BNC male Cable, Anritsu Model 2000-1627-R

### Procedure

1. Connect a BNC cable between the output connector of the external Time Base Reference to the Reference Input connector of the Frequency Counter.
2. Turn on the Frequency Counter.
3. Press the **On/Off** key to turn on the VNA Master.
4. Press the **Shift** key and then the **Mode (9)** key. Use the rotary knob to highlight Vector Network Analyzer and then press the **Enter** key to switch to VNA mode.
5. Press the **Shift** key and then the **Preset (1)** key. Press the Preset button on the touch screen submenu to set the instrument to the factory preset state.

<b>Note</b> Before continuing, allow a 30-minute warm up for the internal circuitry to stabilize.
---

6. Press the **Measure** button on the touch screen main menu. Then press the S Parameter submenu button. Select S21.
7. Press the Number of Traces submenu button and then press 1.
8. Press the Graph Type submenu button. Use the rotary knob to highlight Log Mag and press the **Enter** key to select it.
9. Press the Maximize Active Trace submenu button.
10. Press the **Sweep** main menu button and then change the Data Point to 1000.

11. Press the **Freq/Dist** main menu button and then the **Start Freq** submenu button.
12. Use the numeric keypad to enter 2.6 and then press the **GHZ** submenu button to set the Start Frequency to 2.6 GHz.
13. Press the **Stop Freq** submenu button.
14. Use the numeric keypad to enter 2.6 and then press the **GHZ** submenu button to set the Stop Frequency to 2.6 GHz.
15. Connect the RF cable between the VNA Port 1 connector of the VNA Master and the RF Input1 connector of the Frequency Counter.
16. On the Frequency Counter, press the **Preset** key.
17. Verify that Frequency Counter ready is 2.6 GHz  $\pm$  6.5 kHz ( $\pm$  2.5 ppm). Record the measured value to the test record in [Appendix A](#).
  - MS2024B – [Table A-1, “VNA Frequency Accuracy” on page A-2](#)
  - MS2025B – [Table A-3, “VNA Frequency Accuracy” on page A-3](#)
  - MS2034B – [Table A-5, “VNA Frequency Accuracy” on page A-4](#)
  - MS2035B – [Table A-30, “VNA Frequency Accuracy” on page A-15](#)

## 2-3 Transmission Dynamic Range

The following test is used to verify the transmission dynamic range of the vector network analyzer. The procedures are automated by using the VNA Master Instrument Test software, CDROM part number 2300-535, in conjunction with the equipment that is listed in the following Equipment Required section.

The software guides you to perform multiple calibrations on the VNA Master for specific frequency bands by using the appropriate calibration tees, to measure the noise floor, and to calculate the Transmission Dynamic Range.

### Equipment Required

- Calibration Tee, N male, Anritsu Model OSLN50-1
- Calibration Tee, N female, Anritsu Model OSLNF50-1
- RF Coaxial Cable, Anritsu Model 15NN50-1.0B
- USB Mini-B male to USB Type A male Cable, Anritsu part number 3-2000-1498
- Personal Computer with Microsoft Windows XP Operating System, USB port, and National Instrument VISA software 4.4.1 or later

### Procedure

1. Install the 15NN50-1.0B N male to N male RF Coaxial Cable to the VNA Port 2 connector. Leave the other end of the cable open.
2. Press the **On/Off** key to turn on the VNA Master.
3. Press the **Shift** key and then the **Mode (9)** key. Use the rotary knob to highlight Vector Network Analyzer and then press the **Enter** key to switch to VNA mode.
4. Press the **Shift** key and then the **Preset (1)** key. Press the **Preset** button on the touch screen submenu to set the instrument to the factory preset state.

<b>Note</b> Before continuing, allow a 30-minute warm up for the internal circuitry to stabilize.
---

5. Turn on Power to the PC controller and allow it to complete the boot-up process.
6. Plug the Mini-B male connector of the USB cable into the VNA Master USB Mini-B port.

7. Plug the USB Type A connector of the USB cable into an open USB port of the PC controller. Load the Anritsu Instrument USB driver when prompted.
8. Run the VNA Master Instrument Test software on the PC.
9. Follow the directions displayed on the computer to perform calibration with the appropriate calibration tees.
10. Follow the directions on the computer to perform measurements of transmission noise floor.
11. Pass/Fail status of the test is displayed on the computer. The software can also provide a hard copy printout of the test result, if desired.
12. Print the test results reported by the software and attach it to the test record in [Appendix A](#).

## 2-4 Return Loss Measurement Accuracy Verification

The following test can be used to verify the accuracy of return loss measurements. Measurement calibration of the VNA Master is required for this test.

### Equipment Required

- Calibration Tee, N male, Anritsu Model OSLN50-1
- 20 dB Offset Termination, N male, Anritsu Model SC7423
- 6 dB Offset Termination, N male, Anritsu Model SC7424

### Procedure

1. Press the **On/Off** key to turn on the VNA Master.
2. Press the **Shift** key and then the **Mode (9)** key. Use the rotary knob to highlight Vector Network Analyzer and then press the **Enter** key to switch to VNA mode.
3. Press the **Shift** key and then the **Preset (1)** key. Press the **Preset** button on the touch screen submenu to set the instrument to the factory preset state.

<b>Note</b> Before continuing, allow a 30-minute warm up for the internal circuitry to stabilize.
---

4. Press the **Measure** button on the touch screen main menu. Then press the S Parameter submenu button. Select S11.
5. Press the **Measure** button on the touch screen main menu. Then press the Number of Traces submenu button and then select 1.
6. Press the Maximize Active Trace submenu button.
7. Press the Graph Type submenu button. Use the rotary knob to highlight Log Mag and press the **Enter** key to select it.
8. Press the **Shift** key and then the **Calibrate (2)** key.
9. Press the Cal Type submenu button. Use the rotary knob to highlight Full S11-Port 1 (S11) and then press the **Enter** key to select it.
10. Press the DUT Port Setup submenu button. Insure that Coax DUT Port 1 is set to N-Conn(M). Press the **Back** submenu button to return to previous menu.
11. Press the **Start Cal** submenu button to begin measurement calibration.
12. Connect the Open of the Calibration Tee to VNA Port 1 connector of the VNA Master.
13. Press the **Enter** key and wait until the measurement is complete.
14. Disconnect the Open and connect the Short of the Calibration Tee to VNA Port 1.
15. Press the **Enter** key and wait until the measurement is complete.

16. Disconnect the Short, connect the Load of the Calibration Tee to VNA Port 1 and then press the **Enter** key.
17. When the Load measurement is complete, press the **Enter** key again to select Calculate and Finish Cal.
18. Press the **Scale** main menu button.
19. Use the numeric keypad to enter 0.4 and then press the dB submenu button to set Resolution Per Div to 0.4 dB.
20. Press the Reference Value submenu button. Use the numeric keypad to enter  $-20$  and then press the dB submenu button.
21. Connect the 20 dB Offset Termination to the VNA Port 1 connector of the VNA Master.
22. Press the **Marker** main menu button.
23. Press the Readout Format submenu button and press Table.
24. Press the Marker Search submenu button and press Peak Search. Record the Marker value.
25. Press Valley Search and record the Marker value.
26. Verify that both the Peak and Valley readings are within  $-20 \pm 1.61$  dB.
27. Disconnect the 20 dB Offset Termination.
28. Press the **Scale** main menu button.
29. Use the numeric keypad to enter 0.2 and then press the dB submenu button to set Resolution Per Div to 0.2 dB.
30. Press the Reference Value submenu button. Use the numeric keypad to enter  $-6$  and then press the dB submenu button.
31. Connect the 6 dB Offset Termination to the VNA Port 1 connector of the VNA Master.
32. Press the **Marker** main menu button.
33. Press the Marker Search submenu button and press Peak Search. Record the Marker value (refer to [Step 37](#)).
34. Press Valley Search and record the Marker value.
35. Verify that both the Peak and Valley readings are within  $-6 \pm 0.95$  dB.
36. Disconnect the 6 dB Offset Termination.
37. Enter the worst case values of the Peak and Valley reading that were recorded for [Step 26](#) and [Step 35](#) into the test record in [Appendix A](#).
  - MS2024B – [Table A-2, “VNA Return Loss Measurement Accuracy” on page A-2](#)
  - MS2025B – [Table A-4, “VNA Return Loss Measurement Accuracy” on page A-3](#)
  - MS2034B – [Table A-6, “VNA Return Loss Measurement Accuracy” on page A-4](#)
  - MS2035B – [Table A-31, “VNA Return Loss Measurement Accuracy” on page A-15](#)



# Chapter 3 — Spectrum Analyzer Performance Verification

## 3-1 Introduction

This chapter contains tests that are used to verify the Spectrum Analyzer performance of VNA Master Models MS2034B and MS2035B. Blank performance verification test records are provided in [Appendix A](#). Make copies of the blank test records and use them to record measured values.

The spectrum analyzer performance verification tests are as follows:

- “Residual Spurious Response” on page 3-2
- “Displayed Average Noise Level (DANL)” on page 3-4
- “Frequency Accuracy” on page 3-6
- “Single Side Band (SSB) Phase Noise” on page 3-8
- “Spurious Response (Second Harmonic Distortion)” on page 3-10
- “Input Related Spurious (IRS) Signals” on page 3-13
- “Resolution Bandwidth Accuracy” on page 3-17
- “Amplitude Accuracy” on page 3-20
- “Third Order Intercept (TOI)” on page 3-30

<b>Caution</b> Verify that all equipment has warmed up for at least 30 minutes before making any measurements.
--

## 3-2 Residual Spurious Response

The following test is used to verify the residual spurious response of the spectrum analyzer of VNA Master models MS2034B and MS2035B.

### Equipment Required

- 50 ohm Termination, Anritsu Model 28N50-2

### Procedure

1. Connect the 50 ohm Termination to the RF In connector of the VNA Master.
2. Press the **On/Off** key to turn on the VNA Master.
3. Press the **Shift** key and then the **Mode (9)** key. Use the rotary knob to highlight Spectrum Analyzer and then press the **Enter** key to switch to Spectrum Analyzer mode.
4. Press the **Shift** key and then the **Preset (1)** key. Press the Preset button on the touch screen submenu to set the instrument to the factory preset state.

<b>Note</b> Before continuing, allow a 30-minute warm up period for the internal circuitry to stabilize.
--

5. Press the **Shift** key and then the **Sweep (3)** key. Then press the Sweep Mode submenu key and then the Performance submenu key.
6. Press the Back button and press the Detection submenu button and then the Peak submenu button.

#### Residual Spurious Test with Preamp Off

7. Press the **Amplitude** button on the touch screen main menu and then the Reference Level button on the touch screen submenu.
8. Use the numeric keypad to enter  $-40$  and press the dBm submenu button.
9. Press the Atten Lvl submenu button.
10. Use the numeric keypad to enter  $0$  and then press the dB submenu button.
11. Make sure that the Pre Amp On/Off submenu button is in the Off position. If the preamp is on, then press the Pre Amp On/Off submenu button to turn it off.
12. Press the **Freq** main menu button and then the Start Freq submenu button.
13. Use the numeric keypad to enter  $10$  and then press the MHz submenu button.
14. Press the Stop Freq submenu button.
15. Use the numeric keypad to enter  $50$  and then press the MHz submenu button.
16. Press the **BW** main menu button and then the RBW submenu button.
17. Use the numeric keypad to enter  $1$  and then press the kHz submenu button.
18. Press the VBW submenu button.
19. Use the numeric keypad to enter  $300$  and then press the Hz submenu button.
20. Wait until one sweep is completed.
21. Press the **Marker** main menu button and then the Peak Search submenu button.

22. Verify that Marker 1 amplitude is  $\leq -90$  dBm.

**Note**

If a spur larger than  $-90$  dBm appears, then wait another full sweep and observe whether the spur reappears at the same point on the second sweep.  
If the spur does not appear at the same point on the second sweep, then the spur on the first sweep was not real.

23. Record the Marker 1 amplitude reading in the following tables in [Appendix A](#).

- MS2034B – [Table A-7, “Spectrum Analyzer Residual Spurious Response with Preamp Off” on page A-4](#)
- MS2035B – [Table A-32, “Spectrum Analyzer Residual Spurious Response with Preamp Off” on page A-16](#)

24. Repeat Step 12 through 23 for the other frequency band settings in [Table A-7](#) for MS2034B or [Table A-32](#) for MS2035B in [Appendix A](#). Change RBW and VBW setting as applicable.

**Residual Spurious Test with Preamp On**

25. Press the **Amplitude** button on the touch screen main menu and then the Reference Level button on the touch screen submenu.
26. Use the numeric keypad to enter  $-50$  and press the dBm submenu button.
27. Press the Atten Lvl submenu button.
28. Use the numeric keypad to enter 0 and then press the dB submenu button.
29. Press the Pre Amp On/Off submenu button to turn it on.
30. Press the **Freq** main menu button and then the Start Freq submenu button.
31. Use the numeric keypad to enter 10 and then press the MHz submenu button.
32. Press the Stop Freq submenu button.
33. Use the numeric keypad to enter 1 and then press the GHz submenu button.
34. Press the **BW** main menu button and then the RBW submenu button.
35. Use the numeric keypad to enter 10 and then press the kHz submenu button.
36. Press the VBW submenu button.
37. Use the numeric keypad to enter 1 and then press the kHz submenu button.
38. Wait until one sweep is completed.
39. Press the **Marker** main menu button and then the Peak Search submenu button.
40. Verify that Marker 1 amplitude is  $\leq -90$  dBm.

**Note**

If a spur larger than  $-90$  dBm appears, then wait another full sweep and observe whether the spur reappears at the same point on the second sweep.  
If the spur does not appear at the same point on the second sweep, then the spur on the first sweep was not real.

41. Record the Marker 1 amplitude reading in [Appendix A](#).

- MS2034B – [Table A-8, “Spectrum Analyzer Residual Spurious Response with Preamp On” on page A-4](#)
- MS2035B – [Table A-33, “Spectrum Analyzer Residual Spurious Response with Preamp On” on page A-16](#)

42. Repeat Step 30 through 41 for the other frequency band settings in [Table A-8](#) for MS2034B or [Table A-33](#) for MS2035B in [Appendix A](#). Change RBW and VBW setting as applicable.

## 3-3 Displayed Average Noise Level (DANL)

The following test is used to verify the Displayed Average Noise Level (DANL) of the spectrum analyzer in the MS2034B and MS2035B VNA Master. This test is performed using the RMS detection mode.

### Equipment Required

- 50 ohm Termination, Anritsu Model 28N50-2

### Procedure

1. Connect the 50 ohm Termination to the RF In connector of the VNA Master.
2. Press the **On/Off** key to turn on the VNA Master.
3. Press the **Shift** key and then the **Mode (9)** key. Use the rotary knob to highlight Spectrum Analyzer and then press the **Enter** key to switch to Spectrum Analyzer mode.
4. Press the **Shift** key and then the **Preset (1)** key. Press the Preset button on the touch screen submenu to set the instrument to the factory preset state.

<b>Note</b> Before continuing, allow a 30-minute warm up period for the internal circuitry to stabilize.
--

5. Press the **Shift** key and then the **Sweep (3)** key, Sweep Mode submenu key and then the Performance submenu key.
6. Press the Back button and press the Detection submenu button and then press the RMS/Avg submenu button.

#### DANL Test with Preamp Off

7. Press the **Amplitude** button on the touch screen main menu and then the Reference Level button on the touch screen submenu.
8. Use the numeric keypad to enter  $-20$  and press the dBm submenu button.
9. Press the Atten Lvl submenu button.
10. Use the numeric keypad to enter  $0$  and then press the dB submenu button.
11. Make sure that the Pre Amp On/Off submenu button is in the Off position. If the preamp is on, then press the Pre Amp On/Off submenu button to turn it off.
12. Press the **Freq** main menu button and then the Start Freq submenu button.
13. Use the numeric keypad to enter  $10$  and then press the MHz submenu button.
14. Press the Stop Freq submenu button.
15. Use the numeric keypad to enter  $2.4$  and then press the GHz submenu button.
16. Press the **BW** main menu button and then the RBW submenu button.
17. Use the numeric keypad to enter  $100$  and then press the kHz submenu button.
18. Press the VBW submenu button.
19. Use the numeric keypad to enter  $1$  and then press the kHz submenu button.
20. Wait until one sweep is completed.
21. Press the **Marker** main menu button and then the Peak Search submenu button.
22. Record the Marker 1 amplitude reading into [Appendix A](#) in the 100 kHz RBW Measured Value column of [Table A-9, "Spectrum Analyzer DANL with Preamp Off" on page A-5](#) for MS2034B or [Table A-34, "Spectrum Analyzer DANL with Preamp Off" on page A-17](#) for MS2035B.

<b>Note</b>	The noise floor consists of totally random signals where a spur is a fixed spike of varying amplitude that is always visible.
-------------	---

23. Repeat Step 12 through Step 22 for other frequency settings in Table A-9 for MS2034B or Table A-34 for MS2035B in Appendix A. Change RBW and VBW setting as applicable.
24. For each measured 100 kHz RBW value in Table A-9 for MS2034B or Table A-34 for MS2035B in Appendix A, normalize it to 10 Hz RBW value by subtracting 40 dB from the 100 kHz RBW measured value.  
For example, if the marker shows a value of  $-100$  dBm at 100 kHz RBW, then the calculated value at 10 Hz RBW is  $-140$  dBm ( $-100$  dBm  $-$  40 dB =  $-140$  dBm).
25. Enter the calculated values into the **10 Hz RBW Calculated Value** column of Table A-9 for MS2034B or Table A-34 for MS2035B in Appendix A.
26. Verify that the calculated value is less than or equal to the value in the **Specification** column of Table A-9 for MS2034B or Table A-34 for MS2035B in Appendix A.

#### DANL Test with Preamp On

27. Press the **Amplitude** button on the touch screen main menu and then the Reference Level button on the touch screen submenu.
28. Use the numeric keypad to enter  $-50$  and press the dBm submenu button.
29. Press the Pre Amp On/Off submenu button to turn the preamp On.
30. Press the **Freq** main menu button and then the Start Freq submenu button.
31. Use the numeric keypad to enter 10 and then press the MHz submenu button.
32. Press the Stop Freq submenu button.
33. Use the numeric keypad to enter 2.4 and then press the GHz submenu button.
34. Wait until one sweep is completed.
35. Press the **Marker** main menu button and then the Peak Search submenu button.
36. Record the Marker 1 amplitude reading into Appendix A in the 100 kHz RBW Measured Value column of Table A-10, “Spectrum Analyzer DANL with Preamp On” on page A-5 for MS2034B or Table A-35, “Spectrum Analyzer DANL with Preamp On” on page A-17 for MS2035B.

<b>Note</b>	The noise floor consists of totally random signals where a spur is a fixed spike of varying amplitude that is always visible.
-------------	---

37. Repeat Step 30 through Step 36 for other frequency settings in Table A-10 for MS2034B or Table A-35 for MS2035B in Appendix A.
38. For each measured 100 kHz RBW value in Table A-10 for MS2034B or Table A-35 for MS2035B in Appendix A, normalize it to 10 Hz RBW value by subtracting 40 dB from the 100 kHz RBW measured value.  
For example, if the marker shows a value of  $-100$  dBm at 100 kHz RBW, then the calculated value at 10 Hz RBW is  $-140$  dBm ( $-100$  dBm  $-$  40 dB =  $-140$  dBm).
39. Enter the calculated values into the 10 Hz RBW Calculated Value column of Table A-10 for MS2034B or Table A-35 for MS2035B in Appendix A.
40. Verify that the calculated value is less than or equal to the value in the Specification column of Table A-10 for MS2034B or Table A-35 for MS2035B in Appendix A.

## 3-4 Frequency Accuracy

The following test is used to verify the CW frequency accuracy of the spectrum analyzer in the MS2034B and MS2035B models of VNA Master.

### Equipment Required

- Synthesized Signal Generator, Anritsu Model MG3692X series
- K(m) to N(f) Adapter, Anritsu Model 34RKNF50
- 10 MHz Reference Standard
- RF Coaxial Cable, Anritsu Model 15NN50-1.5C
- BNC(m) to BNC(m) Coaxial Cable, Anritsu part number 2000-1627-R

### Procedure

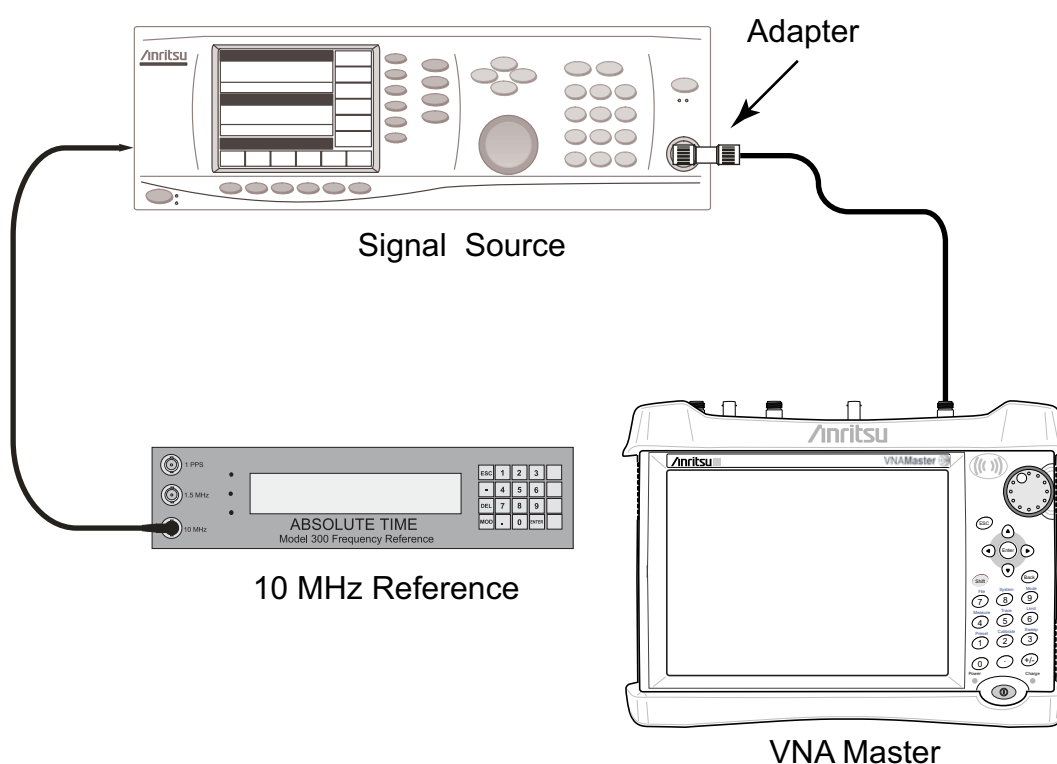

**Figure 3-1.** CW Frequency Accuracy Test Characterization

1. Connect BNC Coaxial Cable between the 10 MHz Reference Standard output and the 10 MHz Ref In connector of the Anritsu MG3692X Synthesized Signal Generator.

**Note** Do not connect the external 10 MHz Reference to the VNA Master.

2. Turn on both the 10 MHz Reference Standard and Synthesized Signal Generator.
3. Set the MG3692X output to 1 GHz CW, with an RF output level of  $-30$  dBm.
4. Install the 34RKNF50 Adapter to the output of the MG3692X Generator and connect the 15NN50-1.5C RF Coaxial Cable between the Adapter and the RF In connector of the VNA Master.
5. Press the **On/Off** key to turn on the VNA Master.
6. Press the **Shift** key and then the **Mode (9)** key. Use the rotary knob to highlight Spectrum Analyzer and then press the **Enter** key to switch to Spectrum Analyzer mode.

7. Press the **Shift** key and then the **Preset (1)** key. Press the Preset button on the touch screen submenu to set the instrument to the factory preset state.
8. Press the **Shift** key and then the **Sweep (3)** key, Sweep Mode submenu key and then the Performance submenu key.
9. Press the **Amplitude** button on the touch screen main menu and then the Reference Level button on the touch screen submenu.
10. Use the numeric keypad to enter  $-10$  and press the dBm submenu button.
11. Press the Span submenu button.
12. Use the numeric keypad to enter 10 and then press the kHz submenu button.
13. Press the **BW** main menu button and then the RBW submenu button.
14. Use the numeric keypad to enter 100 and then press the Hz submenu button.
15. Press the VBW submenu button.
16. Use the numeric keypad to enter 30 and then press the Hz submenu button.
17. Press the **Freq** main menu button and then the Center Freq submenu button.
18. Use the numeric keypad to enter 1 and then press the GHz submenu button.
19. Press the **Marker** main menu button and then the More submenu button.
20. Set Counter Marker to On, press the Back submenu button, and then press the Peak Search submenu button.

**Note** Without the Counter Marker On, the frequency resolution will not allow looking at the kHz accuracy.

21. Verify that the marker frequency reading is within specification and record the measured value into the following tables in [Appendix A](#).
  - MS2034B – [Table A-11, “Spectrum Analyzer Frequency Accuracy” on page A-5](#)
  - MS2035B – [Table A-36, “Spectrum Analyzer Frequency Accuracy” on page A-18](#)
22. Repeat Step 17 through Step 21 for the other frequencies in [Table A-11](#) for MS2034B or [Table A-36](#) for MS2035B in [Appendix A](#).

**Note** If the instrument fails this test, then contact your local Anritsu Service Center (<http://www.anritsu.com/Contact.asp>).

## Related Tests

Frequency Accuracy with GPS On (refer to [Section 4-4 “Spectrum Analyzer Frequency Accuracy with GPS On” on page 4-6](#)):

- MS2034B – [Table A-12, “Spectrum Analyzer Frequency Accuracy with GPS On” on page A-5](#)
- MS2035B – [Table A-37, “Spectrum Analyzer Frequency Accuracy with GPS On” on page A-18](#)

## 3-5 Single Side Band (SSB) Phase Noise

This test is used to verify the single side band (SSB) phase noise of the spectrum analyzer in the MS2034B and MS2035B models of VNA Master.

### Equipment Required

- Synthesized Signal Generator, Anritsu Model MG3692X
- K(m) to N(f) Adapter, Anritsu Model 34RKNF50
- 10 MHz Reference Standard
- RF Coaxial Cable, Anritsu Model 15NN50-1.5C
- BNC(m) to BNC(m) Coaxial Cable, Anritsu part number 2000-1627-R

### Procedure

1. Connect the BNC Coaxial Cable between the 10 MHz Reference Standard output and the 10 MHz Ref In connector of the Anritsu MG3692X Synthesized Signal Generator.
2. Turn both the 10 MHz Reference Standard and the Synthesized Signal Generator on.
3. Set the MG3692X output to 1 GHz CW, with an RF output level of +0 dBm.
4. Install the 34RKNF50 Adapter to the output of the MG3692X and then connect the 15NN50-1.5C RF Coaxial Cable between the Adapter and the RF In connector of the VNA Master.
5. Press the **On/Off** key to turn on the VNA Master.
6. Press the **Shift** key and then the **Mode (9)** key. Use the rotary knob to highlight Spectrum Analyzer and then press the **Enter** key to switch to Spectrum Analyzer mode.
7. Press the **Shift** key and then the **Preset (1)** key. Press the Preset button on the touch screen submenu to set the instrument to the factory preset state.
8. Press the **Shift** key and then the **Sweep (3)** key, Sweep Mode submenu key and then the Performance submenu key.
9. Press the **Amplitude** button on the touch screen main menu and then the Reference Level button on the touch screen submenu.
10. Use the numeric keypad to enter 0 and press the dBm submenu button.
11. Press the Atten Lvl submenu button.
12. Use the numeric keypad to enter 15 and then press the dB submenu button.
13. Press the **Freq** main menu button and then the Center Freq submenu button.
14. Use the numeric keypad to enter 1 and then press the GHz submenu button.
15. Press the Span submenu button.
16. Use the numeric keypad to enter 110 and then press the kHz submenu button.
17. Press the **BW** main menu button and then the RBW submenu button.
18. Use the numeric keypad to enter 1 and then press the kHz submenu button.
19. Press the VBW submenu button.
20. Use the numeric keypad to enter 3 and then press the Hz submenu button.
21. Press the **Shift** key, press the **Trace (5)** key and then press the Trace A Operations submenu button.
22. Press the # of Averages submenu button.
23. Use the numeric keypad to enter 7, and then press the **Enter** key.
24. Wait until the Trace Count displays “7/7”.
25. Press the **Marker** main menu button and then Peak Search submenu button.



26. Press the Delta On/Off submenu button to turn On Delta.
27. Use the numeric keypad to enter 10 and then press the kHz submenu button.
28. Record the measured value in [Appendix A](#).
  - MS2034B – [Table A-13](#), “Spectrum Analyzer SSB Phase Noise” on page A-6
  - MS2035B – [Table A-38](#), “Spectrum Analyzer SSB Phase Noise” on page A-18
29. Subtract 30 dB from the measured value and verify that the result is better than –100 dBc/Hz (for 10 kHz offset) or –105 dBc/Hz (for 100 kHz offset) or –115 dBc/Hz (for 1 MHz offset) and record the calculated values in [Table A-13](#) for MS2034B or [Table A-38](#) for MS2035B in [Appendix A](#).

For example: –70 dBc (measured) –30 dB = –100 dBc/Hz
30. Repeat Step [15](#) through Step [29](#) for 100 kHz offset (set Span to 220 kHz) and 1 MHz offset (set Span to 2.04 MHz). Record the measured values and calculated values in [Table A-13](#) for MS2034B or [Table A-38](#) for MS2035B in [Appendix A](#).

## 3-6 Spurious Response (Second Harmonic Distortion)

The following test is used to verify the input related spurious response of the spectrum analyzer in the MS2034B and MS2035B.

### Equipment Required

- Synthesized Signal Generator, Anritsu Model MS3692X
- K(m) to N(f) Adapter, Anritsu Model 34RKNF50
- 10 MHz Reference Standard
- RF Coaxial Cable, Anritsu Model 15NN50-1.5C
- 50 MHz Low Pass Filter, Anritsu part number 1030-96
- BNC(m) to BNC(m) Coaxial Cable, Anritsu part number 2000-1627-R

### Procedure

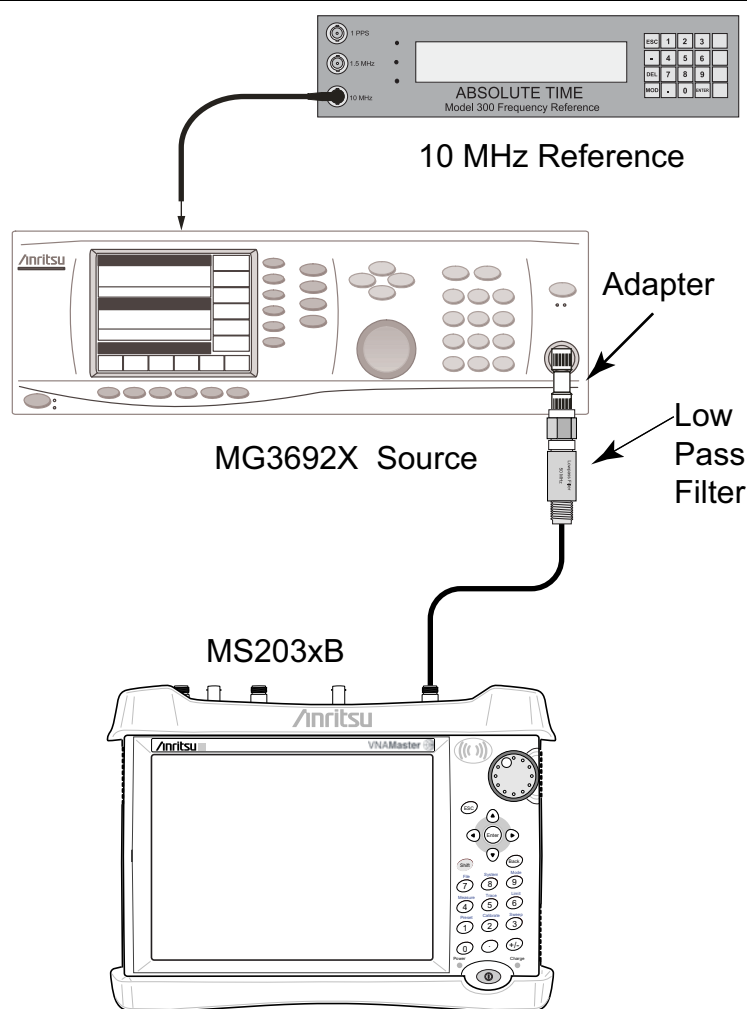

**Figure 3-2.** Second Harmonic Distortion – Spurious Response

1. Connect the BNC Coaxial Cable between the 10 MHz Reference Standard output and the 10 MHz Ref In connector of the Anritsu MG3692X Synthesized Signal Generator.
2. Turn both the 10 MHz Reference Standard and the Synthesized Signal Generator on.
3. Set the MG3692X output to 50.1 MHz CW, with an RF output level of  $-30$  dBm.

4. Install the 34RKNF50 Adapter to the output of the MG3692X Generator and then connect the male end of the 50 MHz Low Pass Filter to the Adapter.
5. Connect the 15NN50-1.5C RF Coaxial Cable between the 50 MHz Low Pass Filter and the RF In connector of the VNA Master.
6. Press the **On/Off** key to turn on the VNA Master.
7. Press the **Shift** key and then the **Mode (9)** key. Use the rotary knob to highlight Spectrum Analyzer and then press the **Enter** key to switch to Spectrum Analyzer mode.
8. Press the **Shift** key and then the **Preset (1)** key. Press the **Preset** button on the touch screen submenu to set the instrument to the factory preset state.
9. Press the **Shift** key and then the **Sweep (3)** key, Sweep Mode submenu key and then the Performance submenu key.
10. Press the **Amplitude** button on the touch screen main menu and then the Reference Level button on the touch screen submenu.
11. Use the numeric keypad to enter  $-27$  and then press the dBm submenu button.
12. Press the Atten Lvl submenu button.
13. Use the numeric keypad to enter 0 and then press the dB submenu button.
14. Press the **Freq** main menu button and then the Center Freq submenu button.
15. Use the numeric keypad to enter 50.1 and then press the MHz submenu button.
16. Press the Span submenu button.
17. Use the numeric keypad to enter 100 and then press the kHz submenu button.
18. Press the **BW** main menu button and then the RBW submenu button.
19. Use the numeric keypad to enter 1 and then press the kHz submenu button.
20. Press the VBW submenu button.
21. Use the numeric keypad to enter 10 and then press the Hz submenu button.
22. Press the **Shift** key and then the **Sweep (3)** key.
23. Press the Detection submenu button and then the Peak submenu button.
24. Press the **Shift** key, press the **Trace (5)** key and then press the Trace A Operations submenu button.
25. Press the # of Averages submenu button.
26. Use the numeric keypad to enter 5, and then press the **Enter** key.
27. Wait until the Trace Count displays “5/5”.
28. Press the **Marker** main menu button and then Peak Search submenu button.
29. Record the amplitude of 50.1 MHz in [Appendix A](#).
  - MS2034B – [Table A-14, “Spectrum Analyzer Spurious Response \(Second Harmonic Distortion” on page A-6](#)
  - MS2035B – [Table A-39, “Spectrum Analyzer Spurious Response \(Second Harmonic Distortion” on page A-19](#)
30. Press the **Freq** main menu button and then the Center Freq submenu button.
31. Use the numeric keypad to enter 100.2 and then press the MHz submenu button.
32. Press the **Shift** key, press the **Trace (5)** key and then press the Trace A Operations submenu button.
33. Press the # of Averages submenu button.
34. Use the numeric keypad to enter 5, and then press the **Enter** key.
35. Wait until the Trace Count displays “5/5”.

36. Press the **Marker** main menu button and then **Peak Search** submenu button.
37. Record the amplitude of 100.2 MHz in [Table A-14](#) for MS2034B or [Table A-39](#) for MS2035B in [Appendix A](#).
38. Calculate the second Harmonic level in dBc by subtracting the 50.1 MHz amplitude from the 100.2 MHz amplitude by using this formula:  
second Harmonic level dBc = 100.2 MHz amplitude – 50.1 MHz amplitude
39. Record the calculated Second Harmonic Level in [Table A-14](#) for MS2034B or [Table A-39](#) for MS2035B in [Appendix A](#) and verify that it is  $\leq -56$  dBc.

## 3-7 Input Related Spurious (IRS) Signals

The following test is used to verify the input related spurious signals of the spectrum analyzer in the MS2034B and MS2035B at different frequencies.

### Equipment Required

- Synthesized Signal Generator, Anritsu Model MS3692X
- K(m) to N(f) Adapter, Anritsu Model 34RKNF50
- 10 MHz Reference Standard
- RF Coaxial Cable, Anritsu Model 15NN50-1.5C
- BNC(m) to BNC(m) Coaxial Cable, Anritsu part number 2000-1627-R

### Procedure

1. Connect the BNC Coaxial Cable between the 10 MHz Reference Standard output and the 10 MHz Ref In connector of the Anritsu MG3692X Synthesized Signal Generator.
2. Turn both the 10 MHz Reference Standard and the Synthesized Signal Generator on.
3. Set the MG3692X RF output level to  $-29$  dBm.
4. Install the 34RKNF50 Adapter to the output of the MG3692X Generator and then connect the 15NN50-1.5C RF Coaxial Cable between the Adapter and the RF In connector of the VNA Master.
5. Press the **On/Off** key to turn on the VNA Master.
6. Press the **Shift** key and then the **Mode (9)** key. Use the rotary knob to highlight Spectrum Analyzer and then **press the Enter** key to switch to Spectrum Analyzer mode.
7. Press the **Shift** key and then the **Preset (1)** key. Press the **Preset** button on the touch screen submenu to set the instrument to the factory preset state.
8. Press the **Shift** key and then the **Sweep (3)** key, **Sweep Mode** submenu key and then the **Performance** submenu key.
9. Press the **Back** button and press the **Detection** submenu button and then the **Peak** submenu button.

#### 2072.5 MHz Input Related Spurious Check

10. Set the MG3692X frequency to 2072.5 MHz CW.
11. On the VNA Master, press the **Amplitude** main menu button and then the **Reference Level** submenu button.
12. Use the numeric keypad to enter  $-27$  and then press the **dBm** submenu button.
13. Press the **Atten Lvl** submenu button.
14. Use the numeric keypad to enter 0 and then press the **dB** submenu button.
15. Press the **Freq** main menu button and then the **Center Freq** submenu button.
16. Use the numeric keypad to enter 2072.5 and then press the **MHZ** submenu button.
17. Press the **Span** submenu button.
18. Use the numeric keypad to enter 2 and then press the **MHZ** submenu button.
19. Press the **BW** main menu button and then the **RBW** submenu button.
20. Use the numeric keypad to enter 1 and then press the **KHZ** submenu button.
21. Press the **VBW** submenu button.
22. Use the numeric keypad to enter 300 and then press the **Hz** submenu button.
23. Wait until one sweep is completed.

24. Press the **Marker** main menu button and then the Peak Search submenu button.
25. Record the Marker amplitude reading of 2072.5 MHz in [Table A-15 on page A-6](#) for MS2034B or [Table A-40 on page A-19](#) for MS2035B in [Appendix A](#).
26. Press the **Freq** main menu button and then the Start Freq submenu button.
27. Use the numeric keypad to enter 1222.5 and then press the MHz submenu button.
28. Press the Stop Freq submenu button.
29. Use the numeric keypad to enter 2072 and then press the MHz submenu button.
30. Wait until one sweep is completed.
31. Press the **Marker** main menu button and then the Peak Search submenu button.
32. Record the Marker amplitude reading into the Measured Value column for 1222.5 MHz to 2072 MHz in [Appendix A](#).
  - MS2034B – [Table A-15, “Spectrum Analyzer Input Related Spurious \(IRS\) Signals” on page A-6](#)
  - MS2035B – [Table A-40, “Spectrum Analyzer Input Related Spurious \(IRS\) Signals” on page A-19](#)
33. Calculate the input related spurious level using the formula below:  
Input Related Spurious dBc = Marker 1 Reading - Amplitude Reading of 2072.5 MHz
34. Record the calculated value into the Calculated IRS column for 1222.5 MHz to 2072 MHz in [Table A-15](#) for MS2034B or [Table A-40](#) for MS2035B in [Appendix A](#) and verify that it is  $\leq -60$  dBc.
35. Repeat Step 26 through Step 34 setting a start frequency of 2073 MHz and a stop frequency of 2922.5 MHz and record the results into the appropriate columns for 2073 MHz to 2922.5 MHz in [Table A-15](#) for MS2034B or [Table A-40](#) for MS2035B in [Appendix A](#).

#### 1220 MHz Input Related Spurious Check

36. Set the MG3692X frequency to 1500 MHz CW.
37. Press the **Freq** main menu button and then the Center Freq submenu button.
38. Use the numeric keypad to enter 1500 and then press the MHz submenu button.
39. Press the Span submenu button.
40. Use the numeric keypad to enter 2 and then press the MHz submenu button.
41. Press the **BW** main menu button and then the RBW submenu button.
42. Use the numeric keypad to enter 3 and then press the kHz submenu button.
43. Press the VBW submenu button.
44. Use the numeric keypad to enter 100 and then press the Hz submenu button.
45. Press the **Shift** key, press the **Trace (5)** key and then press the Trace A Operations submenu button.
46. Press the # of Averages submenu button.
47. Use the numeric keypad to enter 5, and then press the **Enter** key.
48. Wait until the Trace Count displays “5/5”.
49. Press the **Marker** main menu button and then Peak Search submenu button.
50. Record the amplitude at 1500 MHz in [Table A-15](#) for MS2034B or [Table A-40](#) for MS2035B in [Appendix A](#).
51. Press the **Freq** main menu button and then the Start Freq submenu button.
52. Use the numeric keypad to enter 1219 and then press the MHz submenu button.
53. Press the Stop Freq submenu button.
54. Use the numeric keypad to enter 1221 and then press the MHz submenu button.

55. Press the **Shift** key, press the Trace (5) key and then press the Trace A Operations submenu button.
56. Press the # of Averages submenu button.
57. Use the numeric keypad to enter 5, and then press the **Enter** key.
58. Wait until the Trace Count displays “5/5”.
59. Press the **Marker** main menu button and then Peak Search submenu button.
60. Record the Marker amplitude reading into the Measured Value column for 1219 MHz to 1221 MHz in [Table A-15 on page A-6](#) for MS2034B or [Table A-40 on page A-19](#) for MS2035B in [Appendix A](#).
61. Calculated the input related spurious level using the formula below:  
$$\text{Input Related Spurious dBc} = \text{Marker 1 Reading} - \text{Amplitude Reading of 1500 MHz}$$
62. Record the calculated value into the Calculated IRS column for 1219 MHz to 1221 MHz in [Table A-15](#) for MS2034B or [Table A-40](#) for MS2035B in [Appendix A](#) and verify that it is  $\leq -52$  dBc.

#### 1690 MHz Input Related Spurious Check

63. Press the **Freq** main menu button and then the Start Freq submenu button.
64. Use the numeric keypad to enter 1689.5 and then press the MHz submenu button.
65. Press the Stop Freq submenu button.
66. Use the numeric keypad to enter 1691.5 and then press the MHz submenu button.
67. Press the **Shift** key, press the Trace (5) key and then press the Trace A Operations submenu button.
68. Press the # of Averages submenu button.
69. Use the numeric keypad to enter 5, and then press the **Enter** key.
70. Wait until the Trace Count displays “5/5”.
71. Press the **Marker** main menu button and then Peak Search submenu button.
72. Record the Marker amplitude reading into the Measured Value column for 1681.5 MHz to 1691.5 MHz in [Table A-15](#) for MS2034B or [Table A-40](#) for MS2035B in [Appendix A](#).
73. Calculated the input related spurious level using the formula below:  
$$\text{Input Related Spurious dBc} = \text{Marker 1 Reading} - \text{Amplitude Reading of 1500 MHz}$$
74. Record the calculated value into the Calculated IRS column for 1689.5 MHz to 1691.5 MHz in [Table A-15](#) for MS2034B or [Table A-40](#) for MS2035B in [Appendix A](#) and verify that it is  $\leq -52$  dBc.

#### 2822 MHz Input Related Spurious Check

75. Press the **Freq** main menu button and then the Start Freq submenu button.
76. Use the numeric keypad to enter 2821 and then press the MHz submenu button.
77. Press the Stop Freq submenu button.
78. Use the numeric keypad to enter 2823 and then press the MHz submenu button.
79. Press the **BW** main menu button and then the RBW submenu button.
80. Use the numeric keypad to enter 10 and then press the kHz submenu button.
81. Press the VBW submenu button.
82. Use the numeric keypad to enter 30 and then press the Hz submenu button.
83. Press the **Shift** key, press the Trace (5) key and then press the Trace A Operations submenu button.
84. Press the # of Averages submenu button.
85. Use the numeric keypad to enter 5, and then press the **Enter** key.
86. Wait until the Trace Count displays “5/5”.

87. Press the **Marker** main menu button and then **Peak Search** submenu button.
88. Record the Marker amplitude reading into the Measured Value column for 2821 MHz to 2823 MHz in [Table A-15 on page A-6](#) for MS2034B or [Table A-40 on page A-19](#) for MS2035B in [Appendix A](#).
89. Calculated the input related spurious level using the formula below:  
$$\text{Input Related Spurious dBc} = \text{Marker 1 Reading} - \text{Amplitude Reading of 1500 MHz}$$
90. Record the calculated value into the Calculated IRS column for 2821 MHz to 2823 MHz in [Table A-15](#) for MS2034B or [Table A-40](#) for MS2035B in [Appendix A](#) and verify that it is  $\leq -52$  dBc.

#### 2506 MHz Input Related Spurious Check

91. Set the MG3692X frequency to 2421.5 MHz CW.
92. On the VNA Master, press the **Freq** main menu button and then the **Center Freq** submenu button.
93. Use the numeric keypad to enter 2421.5 and then press the MHz submenu button.
94. Press the **Span** submenu button.
95. Use the numeric keypad to enter 2 and then press the MHz submenu button.
96. Press the **BW** main menu button and then the **RBW** submenu button.
97. Use the numeric keypad to enter 10 and then press the kHz submenu button.
98. Press the **VBW** submenu button.
99. Use the numeric keypad to enter 1 and then press the kHz submenu button.
100. Press the **Shift** key, press the **Trace (5)** key and then press the **Trace A Operations** submenu button.
101. Press the **# of Averages** submenu button.
102. Use the numeric keypad to enter 5, and then press the **Enter** key.
103. Wait until the Trace Count displays "5/5".
104. Press the **Marker** main menu button and then the **Peak Search** submenu button.
105. Record the Marker amplitude reading of 2421.5 MHz in [Table A-15](#) for MS2034B or [Table A-40](#) for MS2035B in [Appendix A](#).
106. Press the **Freq** main menu button and then the **Start Freq** submenu button.
107. Use the numeric keypad to enter 2505 and then press the MHz submenu button.
108. Press the **Stop Freq** submenu button.
109. Use the numeric keypad to enter 2507 and then press the MHz submenu button.
110. Press the **Shift** key, press the **Trace (5)** key and then press the **Trace A Operations** submenu button.
111. Press the **# of Averages** submenu button.
112. Use the numeric keypad to enter 5, and then press the **Enter** key.
113. Wait until the Trace Count displays "5/5".
114. Press the **Marker** main menu button and then the **Peak Search** submenu button.
115. Record the Marker amplitude reading into the Measured Value column for 2505 MHz to 2507 MHz in [Table A-15](#) for MS2034B or [Table A-40](#) for MS2035B in [Appendix A](#).
116. Calculated the input related spurious level using the formula below:  
$$\text{Input Related Spurious dBc} = \text{Marker 1 Reading} - \text{Amplitude Reading of 2421.5 MHz}$$
117. Record the calculated value into the Calculated IRS column for 2505 MHz to 2507 MHz in [Table A-15](#) for MS2034B or [Table A-40](#) for MS2035B in [Appendix A](#) and verify that it is  $\leq -39$  dBc.



### 3-8 Resolution Bandwidth Accuracy

The following test is used to verify the resolution bandwidth accuracy of the spectrum analyzer in the MS2034B and MS2035B VNA Master.

#### Equipment Required

- Synthesized Signal Generator, Anritsu Model MS3692X
- K(m) to N(f) Adapter, Anritsu Model 34RKNF50
- 10 MHz Reference Standard
- RF Coaxial Cable, Anritsu Model 15NN50-1.5C
- BNC(m) to BNC(m) Coaxial Cable (Quantity 2), Anritsu part number 2000-1627-R
- BNC Tee Adapter, BNC(m) to BNC(f)/BNC(f), Anritsu part number 3-2600-2

#### Procedure

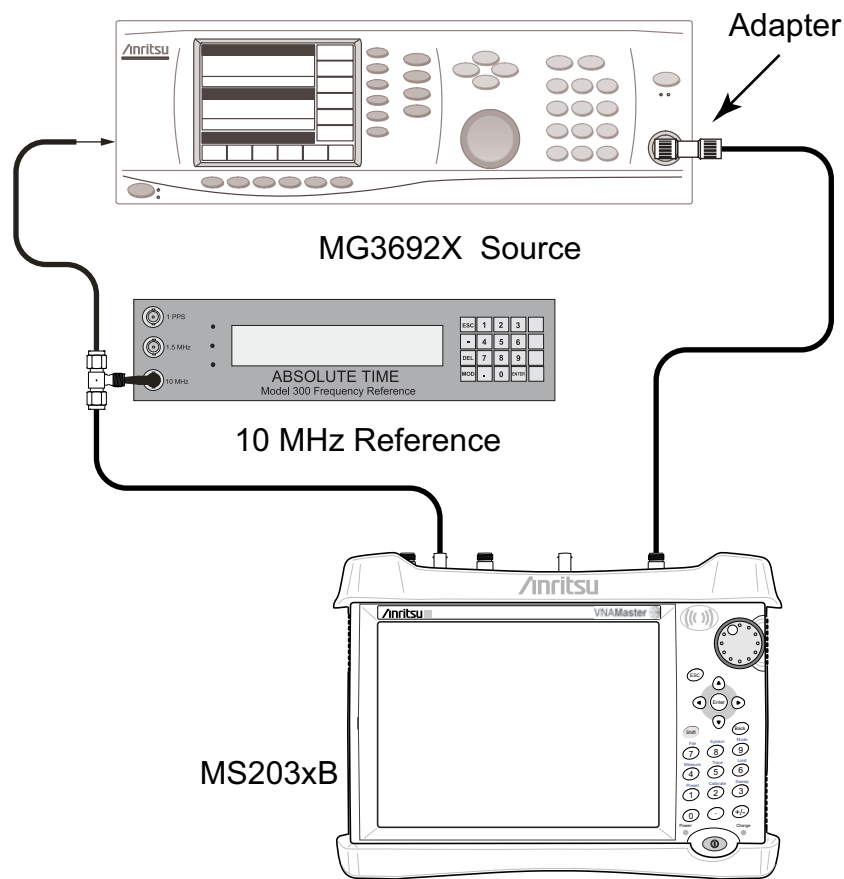

**Figure 3-3.** Resolution Bandwidth Accuracy Test

1. Connect the BNC Tee Adapter to the output of the 10 MHz Reference Standard.
2. Connect a BNC Coaxial Cable between the BNC Tee Adapter and the 10 MHz Ref In connector of the Anritsu MG3692X Synthesized Signal Generator.
3. Connect a BNC Coaxial Cable between the BNC Tee Adapter and the External Ref In connector of the VNA Master.
4. Turn both the 10 MHz Reference Standard and the Synthesized Signal Generator on.
5. Set the MG3692X RF output frequency to 1 GHz CW and level to  $-30$  dBm.

6. Install the 34RKNF50 Adapter to the output of the MG3692X Generator and then connect the 15NN50-1.5C RF Coaxial Cable between the Adapter and the RF In connector of the VNA Master.
7. Press the **On/Off** key to turn on the VNA Master.
8. Press the **Shift** key and then the **Mode (9)** key. Use the rotary knob to highlight Spectrum Analyzer and then press the **Enter** key to switch to Spectrum Analyzer mode.
9. Press the **Shift** key and then the **Preset (1)** key. Press the Preset button on the touch screen submenu to set the instrument to the factory preset state.
10. Press the **Shift** key and then the **Sweep (3)** key, Sweep Mode submenu key and then the Performance submenu key.
11. Press the **Amplitude** main menu button and then the Reference Level submenu button.
12. Use the numeric keypad to enter  $-10$  and then press the dBm submenu button.
13. Press the Atten Lvl submenu button.
14. Use the numeric keypad to enter  $0$  and then press the dB submenu button.
15. Press the Scale submenu button.
16. Use the numeric keypad to enter  $10$  and then press the dB/div submenu button.
17. Press the **Freq** main menu button and then the Center Freq submenu button.
18. Use the numeric keypad to enter  $1$  and then press the GHz submenu button.

**RBW Test**

19. Press the Span submenu button.
20. Use the numeric keypad and the appropriate unit submenu button (for example, MHz) to set Span to the first value listed in the table in [Appendix A](#). Refer to the Span column of the Table.
  - MS2034B – [Table A-16](#), “Spectrum Analyzer Resolution Bandwidth Accuracy” on page A-7
  - MS2035B – [Table A-41](#), “Spectrum Analyzer Resolution Bandwidth Accuracy” on page A-20
21. Press the **BW** main menu button and then the RBW submenu button.
22. Use the numeric keypad and the appropriate unit submenu button (for example, MHz) to set RBW to the first value listed in [Table A-16](#) for MS2034B or [Table A-41](#) for MS2035B in [Appendix A](#).
23. Press the VBW submenu button.
24. Use the numeric keypad and the appropriate unit submenu button (for example, MHz) to set VBW to the first value listed in [Table A-16](#) for MS2034B or [Table A-41](#) for MS2035B in [Appendix A](#).
25. Press the **Shift** key and then the **Measure (4)** key.
26. Press the OCC BW submenu button and then dBc submenu button.
27. Use the numeric keypad to enter 3 and then press the **Enter** key.
28. Press the OCC BW On/Off submenu button to turn occupied bandwidth measurement on.
29. Record the OCC BW reading into the Measured Value column of [Table A-16](#) for MS2034B or [Table A-41](#) for MS2035B in [Appendix A](#).
30. Verify that the OCC BW reading frequency is within  $\pm 10\%$  of the RBW.
31. Repeat Step 19 through Step 30 for other settings and record the results into [Table A-16](#) for MS2034B or [Table A-41](#) for MS2035B in [Appendix A](#).

## 3-9 Amplitude Accuracy

The following tests are used to verify the amplitude accuracy of the spectrum analyzer in the MS2034B and MS2035B VNA Master. The tests consist of:

- “50 MHz Amplitude Accuracy Verification”
- “Amplitude Accuracy Across Frequency Verification”

### 50 MHz Amplitude Accuracy Verification

#### Equipment Required

- Synthesized Signal Generator, Anritsu Model MG3692X
- K(m) to N(f) Adapter, Anritsu Model 34RKNF50
- 10 MHz Reference Standard
- BNC(m) to BNC(m) Coaxial Cable, Anritsu part number 2000-1627-R
- Dual Channel Power Meter, Anritsu Model ML2438A
- High Accuracy Power Sensors (Quantity 2), Anritsu Model SC7400
- RF Coaxial Cable, Anritsu Model 15NN50-1.5C
- Power Splitter, Aeroflex/Weinschel Model 1870A
- 10 dB Fixed Attenuator, Aeroflex/Weinschel Model 44-10
- N(m) to N(m) Adapter, Anritsu Model 34NN50A

#### Procedure

##### Test Setup Characterization

1. Turn on the 10 MHz Reference Standard, the ML2438A Power Meter, the MG3692X Signal Generator, and the Model MS20xxB VNA Master.

<b>Note</b> Before continuing, allow a 30-minute warm up period for the internal circuitry to stabilize.
--

2. Install the 34RKNF50 Adapter to the MG3692X Signal Generator output and then connect the 15NN50-1.5C Cable to the 34RKNF50 Adapter.
3. Connect the Power Splitter to the open end of the 15NN50-1.5C Cable.
4. On the power meter, press the **Channel** front panel key, the **Setup** soft key and then the **Channel** soft key to display Channel 2 Setup menu.
  - a. Press the **Input** key twice to set the Input Configuration to B.
  - b. Press the **Sensor** key to display both Sensor A and Sensor B readings.
  - c. Connect the power sensors to the Calibrator port of the power meter and calibrate the sensors.
  - d. Press the **Sensor** key, the **Cal Factor** soft key, and then the **Freq** soft key.
  - e. Use the numeric keypad to enter 50 MHz as the input signal frequency. Do this for both Sensor A and Sensor B. This sets the power meter to use the proper power sensor cal factor.
5. Connect Sensor B to one of the Power Splitter outputs.

6. Install the 10 dB Fixed Attenuator to the other Power Splitter output and then connect Sensor A to the end of the attenuator as shown in [Figure 3-4](#).

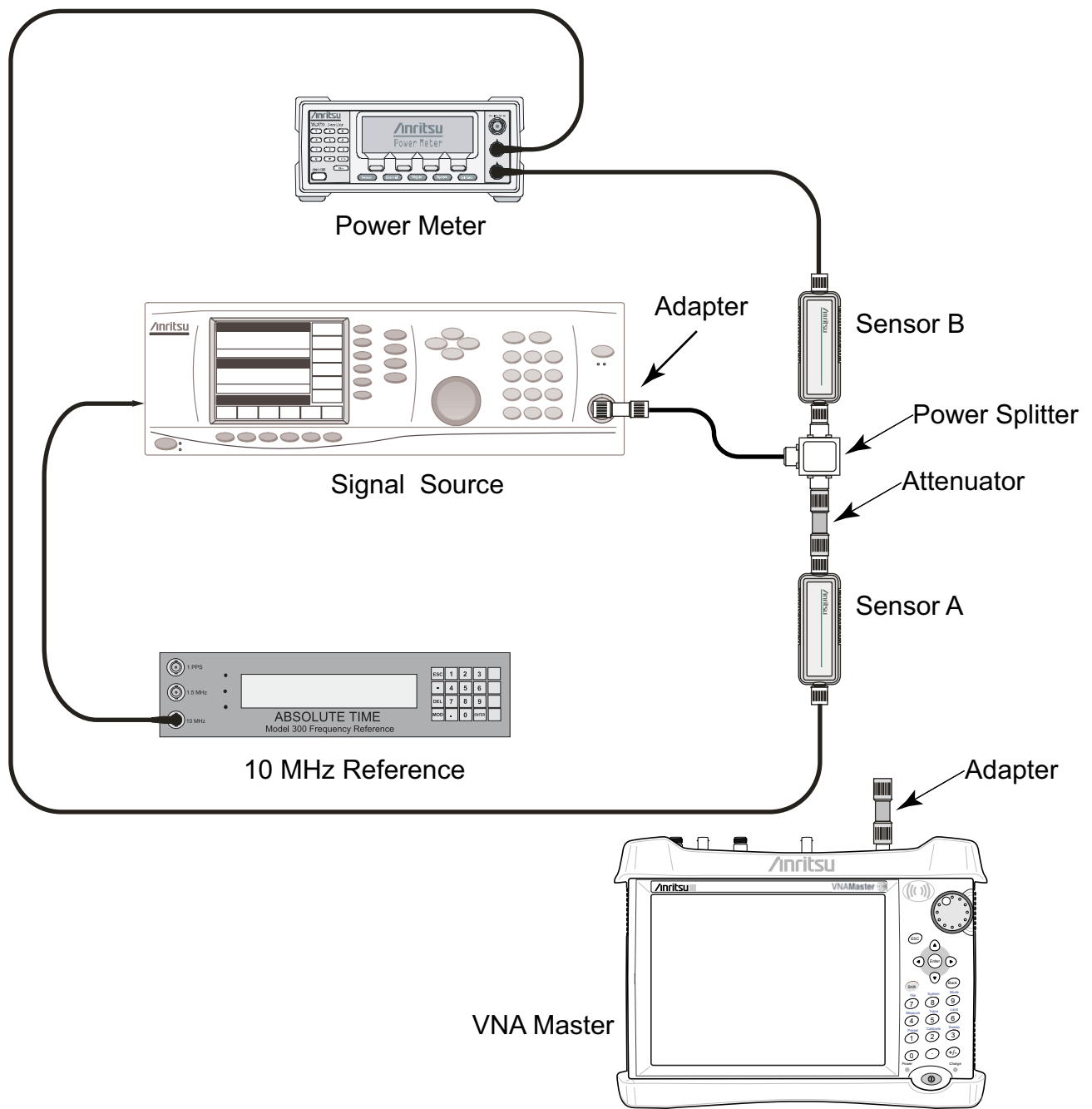

**Figure 3-4.** Absolute Amplitude Accuracy Verification Pretest Setup

7. Set the MG3692X to a frequency of 50 MHz.
8. Starting with 0 dBm, adjust the power level of the MG3692X to get a reading on Sensor A that matches the power level into the Test Power Level @ 50 MHz columns of the following tables in [Appendix A](#).
  - MS2034B – [Table A-17, “Spectrum Analyzer 50 MHz Amplitude Accuracy Setup Table” on page A-8](#)
  - MS2035B – [Table A-42, “Spectrum Analyzer 50 MHz Amplitude Accuracy Setup Table” on page A-21](#)

9. Record the Sensor B reading into the Required Sensor B Reading column of [Table A-17](#) for MS2034B or [Table A-42](#) for MS2035B in [Appendix A](#).
10. Repeat [Step 8](#) and [Step 9](#) for the other input levels from  $-4$  dBm to  $-50$  dBm.

### 50 MHz Amplitude Accuracy Measurements

11. Disconnect Sensor A from the 10 dB Fixed Attenuator and then install the 34NN50A Adapter to the end of the attenuator.

**Note**

To maintain test setup integrity, do not disconnect Sensor B, the Power Splitter or the Fixed Attenuator.

12. Connect the open end of the 34NN50A Adapter to the RF In connector of the VNA Master as shown in [Figure 3-5](#).

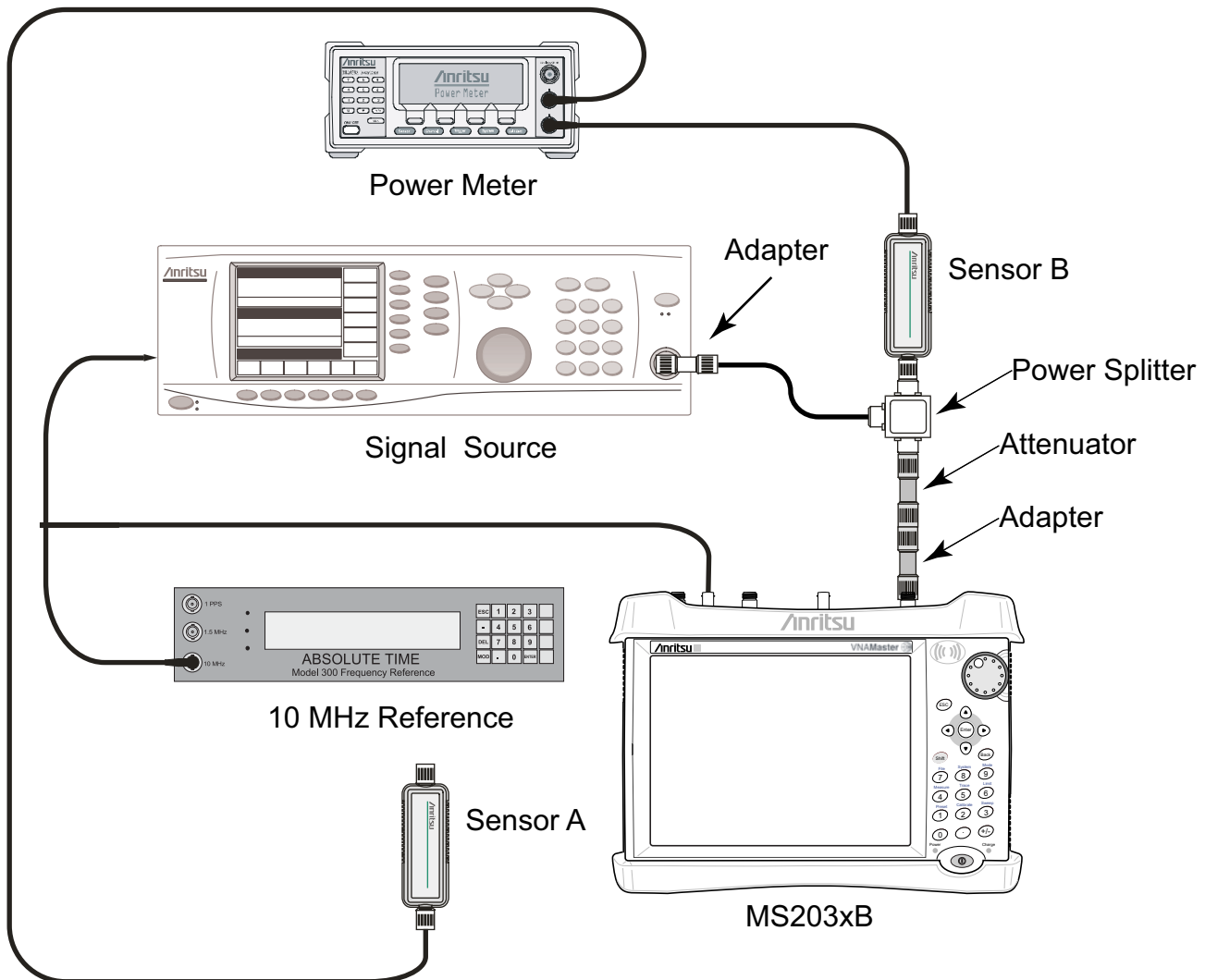

**Figure 3-5.** 50 MHz Amplitude Accuracy Verification Test Setup

13. On the VNA Master, press the **Shift** key and then the **Mode (9)** key. Use the rotary knob to highlight Spectrum Analyzer and then press the **Enter** key to switch to Spectrum Analyzer mode.
14. Press the **Shift** key and then the **Preset (1)** key. Press the Preset button on the touch screen submenu to set the instrument to the factory preset state.

15. Press the **Shift** key and then the **Sweep (3)** key, Sweep Mode submenu key and then the Performance submenu key.
16. Press the **Freq** main menu button and then the Center Freq submenu button.
17. Use the numeric keypad to enter 50 and then press the MHz submenu button.
18. Press the **BW** main menu button and then the RBW submenu button.
19. Use the numeric keypad to enter 1 and then press the kHz submenu button.
20. Press the VBW submenu button.
21. Use the numeric keypad to enter 10 and then press the Hz submenu button.
22. Press the **Span** main menu button.
23. Use the numeric keypad to enter 10 and then press the kHz submenu button.
24. Press the **Amplitude** main menu button and then the Reference Level submenu button.
25. Use the numeric keypad to enter 10 and then press the dBm submenu button.
26. Press the Atten Lvl submenu button.
27. Use the numeric keypad to enter 30 and then press the dB submenu button.
28. Adjust the power level on the MG3692X so that the power meter displays the corresponding desired Sensor B reading as recorded for 0 dBm in the Required Sensor B Reading column of [Table A-17](#) for MS2034B or [Table A-42](#) for MS2035B in [Appendix A](#).
29. Press the **Marker** main menu button and then the Peak Search submenu button.
30. Record the Marker 1 amplitude reading in the 0 dBm rows of the following tables in [Appendix A](#).
  - MS2034B – [Table A-18](#), “Spectrum Analyzer 50 MHz Amplitude Accuracy” on page A-8
  - MS2035B – [Table A-43](#), “Spectrum Analyzer 50 MHz Amplitude Accuracy” on page A-21
31. Repeat Step 28 through Step 30 for the other power level settings. Change Reference Level and Atten Lvl setting as required. Refer to [Table A-17](#) for MS2034B or [Table A-42](#) for MS2035B in [Appendix A](#) for Required Sensor B Readings. Use [Table A-18](#) for MS2034B or [Table A-43](#) for MS2035B in [Appendix A](#) to record test results.
32. Calculate deviation values of all input levels by subtracting the value in the Test Level column from the value in Marker 1 amplitude reading column. Enter the results into the Deviation column of [Table A-18](#) for MS2034B or [Table A-43](#) for MS2035B in [Appendix A](#).
33. Verify that all deviation values are within the specification.

## Amplitude Accuracy Across Frequency Verification

### Equipment Required

- Synthesized Signal Generator, Anritsu Model MG3692X
- K(m) to N(f) Adapter, Anritsu Model 34RKNF50
- 10 MHz Reference Standard
- BNC(m) to BNC(m) Coaxial Cable, Anritsu part number 2000-1627-R
- Dual Channel Power Meter, Anritsu Model ML2438A
- High Accuracy Power Sensors (Quantity 2), Anritsu Model SC7400
- RF Coaxial Cable, Anritsu Model 15NN50-1.5C
- Power Splitter, Aeroflex/Weinschel Model 1870A
- 10 dB Fixed Attenuator, Aeroflex/Weinschel Model 44-10
- N(m) to N(m) Adapter, Anritsu Model 34NN50A

### Procedure

#### Test Setup Characterization

1. Turn on the 10 MHz Reference Standard, the ML2438A Power Meter, the MG3692X Signal Generator, and the MS20XXB VNA Master.

<b>Note</b> Before continuing, allow a 30-minute warm up period for the internal circuitry to stabilize.
--

2. Install the 34RKNF50 Adapter to the MG3692X Signal Generator output and then connect the 15NN50-1.5C Cable to the 34RKNF50 Adapter.
3. Connect the Power Splitter to the open end of the 15NN50-1.5C Cable.
4. Connect Sensor B to one of the Power Splitter outputs



5. Install the 10 dB Fixed Attenuator to the other Power Splitter output and then connect Sensor A to the end of the attenuator as shown in [Figure 3-6](#).

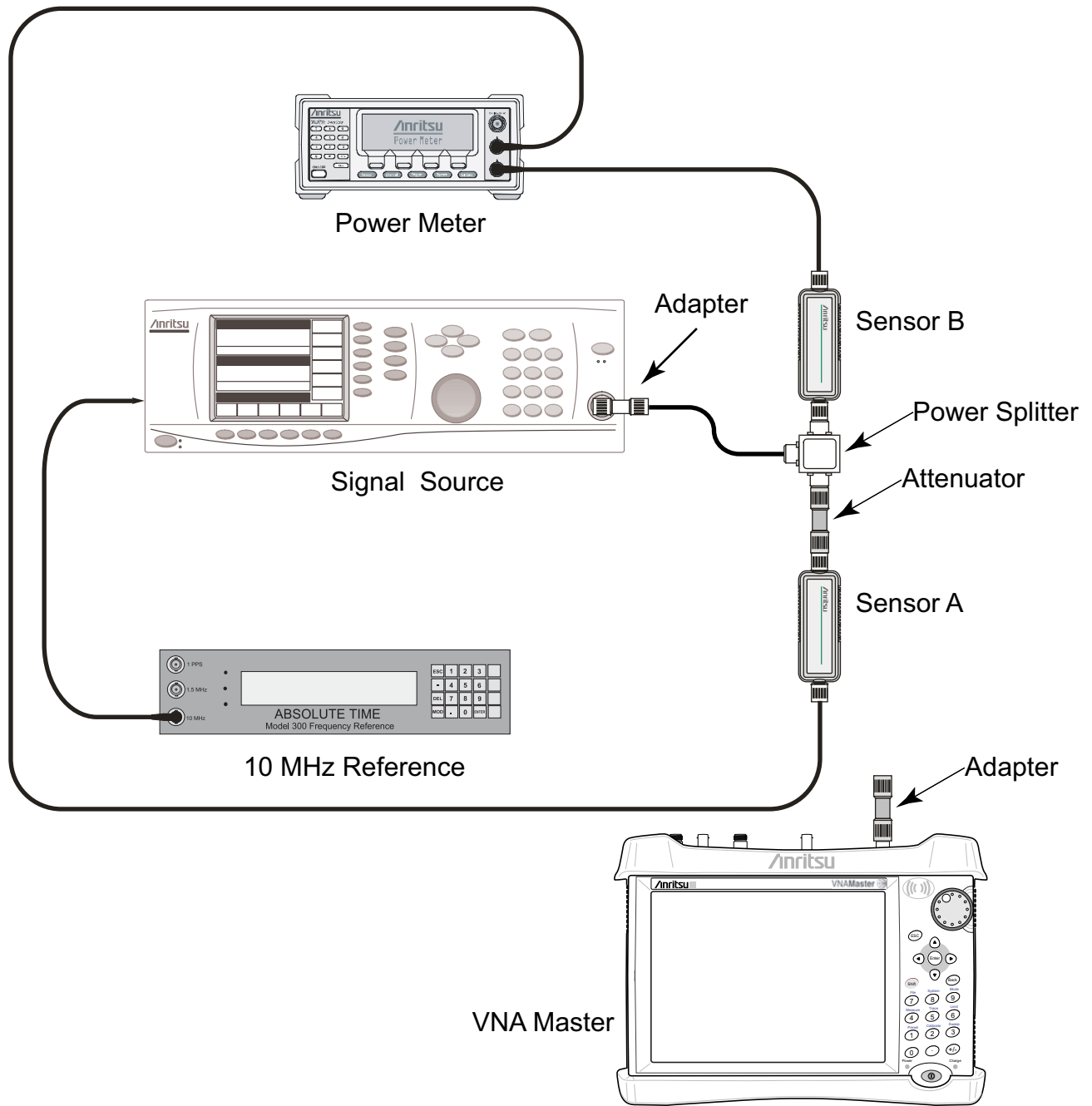

**Figure 3-6.** Fixed Amplitude Level with Varying Frequency Setup

6. On the power meter, press the **Channel** front panel key, the **Setup** soft key and then the **Channel** soft key to display Channel 2 Setup menu.
  - a. Press the **Input** key twice to set the Input Configuration to B.
  - b. Press the **Sensor** key to display both Sensor A and Sensor B readings.
  - c. Connect the power sensors to the Calibrator port of the power meter and calibrate the sensors.
7. Set the MG3692X frequency to 100 kHz.

8. On the power meter, press the **Sensor** key, the **Cal Factor** soft key, and then the **Freq** soft key. Use the numeric keypad to enter the value matching the frequency of MS3692X as the input signal frequency. Do this for both Sensor A and Sensor B. This sets the power meter to use the proper power sensor cal factor. Press the **System** key to display the power reading.
9. Adjust the MG3692X output level so that Sensor A reading is  $-2 \text{ dBm} \pm 0.1 \text{ dB}$ .
10. Record the Sensor B reading into the  $-2 \text{ dBm}$  columns of the following tables in [Appendix A](#).
  - MS2034B – [Table A-19, “Spectrum Analyzer Amplitude Accuracy Across Frequency Setup Table” on page A-9](#)
  - MS2035B – [Table A-44, “Spectrum Analyzer Amplitude Accuracy Across Frequency Setup Table” on page A-22](#)
11. Adjust the MG3692X output level so that Sensor A reading is  $-30 \text{ dBm} \pm 0.1 \text{ dB}$ .
12. Record the Sensor B reading into the  $-30 \text{ dBm}$  column of [Table A-19](#) for MS2034B or [Table A-36](#) for MS2035B in [Appendix A](#).
13. Repeat Step 7 through Step 12 for all the frequencies listed in [Table A-19](#) for MS2034B or [Table A-36](#) for MS2035B in [Appendix A](#).

#### Amplitude Across Frequency Measurements

14. Disconnect Sensor A from the 10 dB Fixed Attenuator and then install the 34NN50A Adapter to the end of the attenuator.

<b>Note</b>	To maintain test setup integrity, do not disconnect Sensor B, the Power Splitter or the Fixed Attenuator.
-------------	---

15. Connect the open end of the 34NN50A Adapter to the RF In connector of the VNA Master as shown in Figure 3-4.

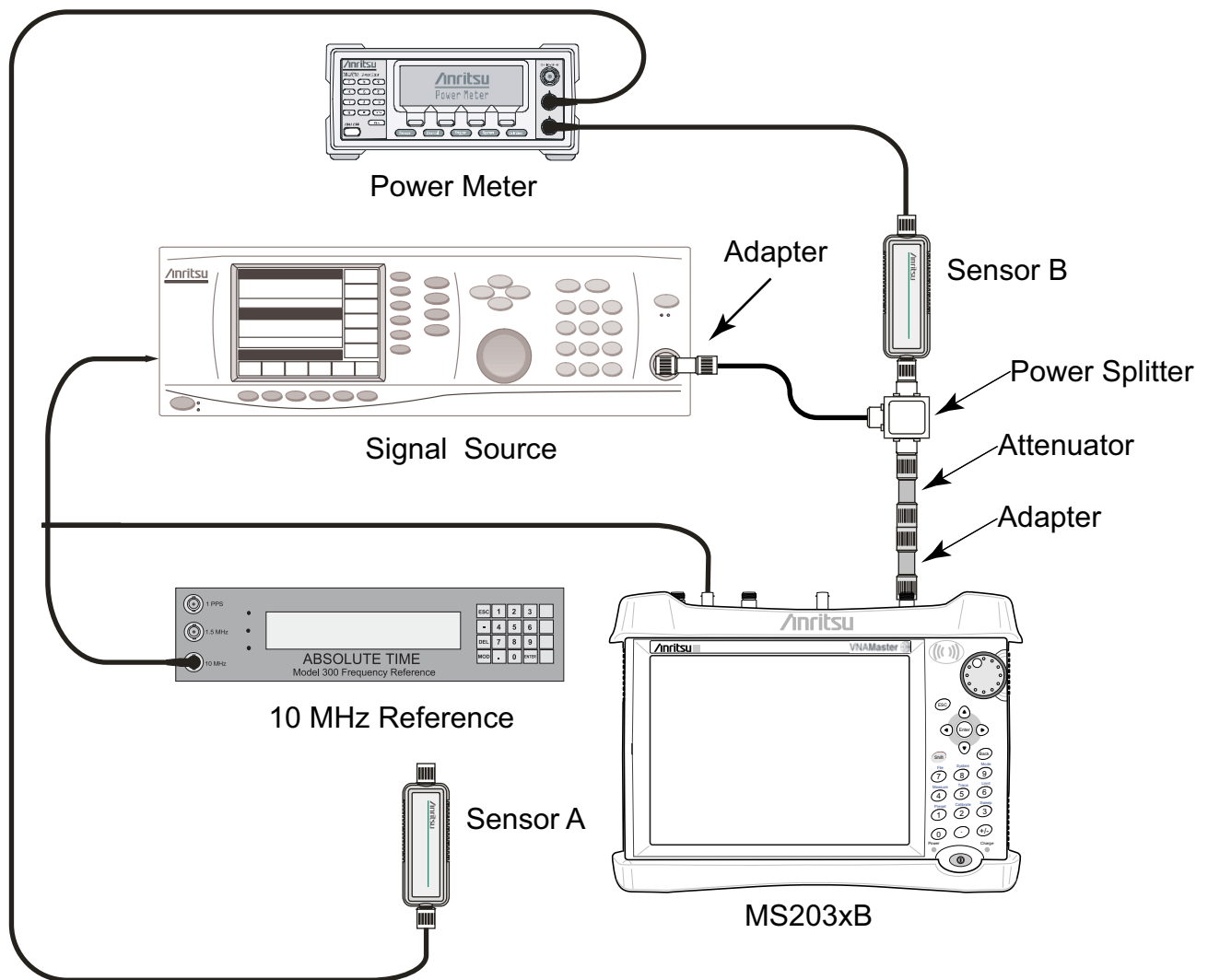

**Figure 3-7.** Amplitude Accuracy Across Frequency Verification Test Setup

16. On the VNA Master, press the **Shift** key and then the **Mode (9)** key. Use the rotary knob to highlight Spectrum Analyzer and then press the **Enter** key to switch to Spectrum Analyzer mode.
17. Press the **Shift** key and then the **Preset (1)** key. Press the Preset button on the touch screen submenu to set the instrument to the factory preset state.
18. Press the **Shift** key and then the **Sweep (3)** key, Sweep Mode submenu key and then the Performance submenu key.
19. Press the **BW** main menu button and then the RBW submenu button.
20. Use the numeric keypad to enter 1 and then press the kHz submenu button.
21. Press the VBW submenu button.
22. Use the numeric keypad to enter 10 and then press the Hz submenu button.
23. Press the **Span** main menu button.
24. Use the numeric keypad to enter 10 and then press the kHz submenu button.
25. Set the MG3692X frequency to 100 kHz CW and power level to  $-30$  dBm.

26. Set the power meter to display Channel B. Press the **Sensor** key, the Cal Factor soft key, and then the Freq soft key. Use the numeric keypad to enter the value matching the frequency of MG3692X as the input signal frequency. This sets the power meter to use the proper power sensor cal factor. Press the **System** key to display the power reading.
27. Adjust the MG3692X output power so that the power meter displays a reading which matches the Sensor B reading for  $-30$  dBm in the following tables in [Appendix A](#).
  - MS2034B – [Table A-19, “Spectrum Analyzer Amplitude Accuracy Across Frequency Setup Table” on page A-9](#)
  - MS2035B – [Table A-44, “Spectrum Analyzer Amplitude Accuracy Across Frequency Setup Table” on page A-22](#)
28. On the VNA Master, press the **Amplitude** main menu button and then the Reference Level submenu button.
29. Use the numeric keypad to enter  $-20$  and then press the dBm submenu button.
30. Press the **Span** main menu button.
31. Use the numeric keypad to enter 10 and then press the kHz submenu button.
32. Press the **Freq** main menu button and then the Center Freq submenu button.
33. Use the numeric keypad to enter 100 and then press the kHz submenu button.
34. Press the **Amplitude** main menu button and then the Atten Lvl submenu button.
35. Use the numeric keypad to enter 0 and then press the dB submenu button. This set the Attenuation Level to 0 dB.
36. Press the **Marker** main menu button and then the Peak Search submenu button.
37. Record the Marker 1 amplitude reading in [Table A-20, “Spectrum Analyzer Amplitude Accuracy Across Frequency – 100 kHz” on page A-9](#) for MS2034B or [Table A-45, “Spectrum Analyzer Amplitude Accuracy Across Frequency – 100 kHz” on page A-22](#) for MS2035B in [Appendix A](#).
38. Calculate the deviation by subtracting  $-30$  dBm from the Marker 1 amplitude reading. Record the result in [Table A-20](#) for MS2034B or [Table A-45](#) for MS2035B in [Appendix A](#).
39. Verify the deviation value is within the specification.
40. Repeat Step 34 through Step 39 for Atten Lvl of 5 dB, 10 dB, and 20 dB.
41. Adjust the MG3692X output power so that the power meter displays a reading which matches the Sensor B reading for  $-2$  dBm in [Table A-19](#) for MS2034B or [Table A-36](#) for MS2035B in [Appendix A](#).
42. On the VNA Master, press the **Amplitude** main menu button and then the Reference Level submenu button.
43. Use the numeric keypad to enter 10 and then press the dBm submenu button.
44. Repeat Step 34 through Step 39 for Atten Lvl of 30 dB, 40 dB, 50 dB, and 55 dB. Calculate the deviation by subtracting  $-2$  dBm from Marker 1 amplitude reading and record the result in [Table A-20](#) for MS2034B or [Table A-45](#) for MS2035B in [Appendix A](#).

45. Repeat Step 25 through Step 44 for all frequencies that are applicable for the unit under test. Record the results in [Appendix A](#) in the following tables for MS2034B:

- [Table A-21 on page A-10](#)
- [Table A-22 on page A-10](#)
- [Table A-23 on page A-11](#)
- [Table A-24 on page A-11](#)
- [Table A-25 on page A-12](#)
- [Table A-26 on page A-12](#)
- [Table A-27 on page A-13](#)
- [Table A-28 on page A-13](#)

Record the results in [Appendix A](#) in the following tables for MS2035B:

- [Table A-46 on page A-23](#)
- [Table A-47 on page A-23](#)
- [Table A-48 on page A-24](#)
- [Table A-49 on page A-24](#)
- [Table A-50 on page A-25](#)
- [Table A-51 on page A-25](#)
- [Table A-52 on page A-26](#)
- [Table A-53 on page A-26](#)
- [Table A-54 on page A-27](#)
- [Table A-55 on page A-27](#)

## 3-10 Third Order Intercept (TOI)

The following test verifies the Third Order Intercept point (also known as TOI or IP3) of the spectrum analyzer in VNA Master Models MS2034B and MS2035B.

### Equipment Required

- Frequency Reference, Symmetricom Model Rubisource T&M
- Synthesized Signal Generator, Anritsu Model MG3692x (Quantity 2)
- Power Splitter, Aeroflex/Weinschel Model 1870A
- Power Meter, Anritsu Model ML2438A
- Power Sensor, Anritsu Model MA2442D
- Fixed Attenuator, Aeroflex/Weinschel Model 44-2 (Quantity 2)
- Fixed Attenuator, Aeroflex/Weinschel Model 44-6 (Quantity 2)
- Fixed Attenuator, Aeroflex/Weinschel Model 44-20 (Quantity 2)
- RF Coaxial Cable, N(m) to N(f), Anritsu Model 15NN50-1.5C (Quantity 2)
- Adapter, Anritsu Model 34NN50A
- Coaxial Cable, BNC(m) to BNC(m), Anritsu Part Number 2000-1627-R (Quantity 3)
- Tee Adapter, BNC(m) to BNC(f)/BNC(f), Anritsu Part Number 3-2600-2 (Quantity 2)

### Procedure

1. Connect the equipment as shown in [Figure 3-8](#). The power splitter will be used as an RF combiner (the normal RF outputs will become inputs, and the normal input will become the RF output). Do not connect the power sensor at present.

<b>Note</b> Ensure that the 10 MHz external reference is connected to the MS203xB.
--

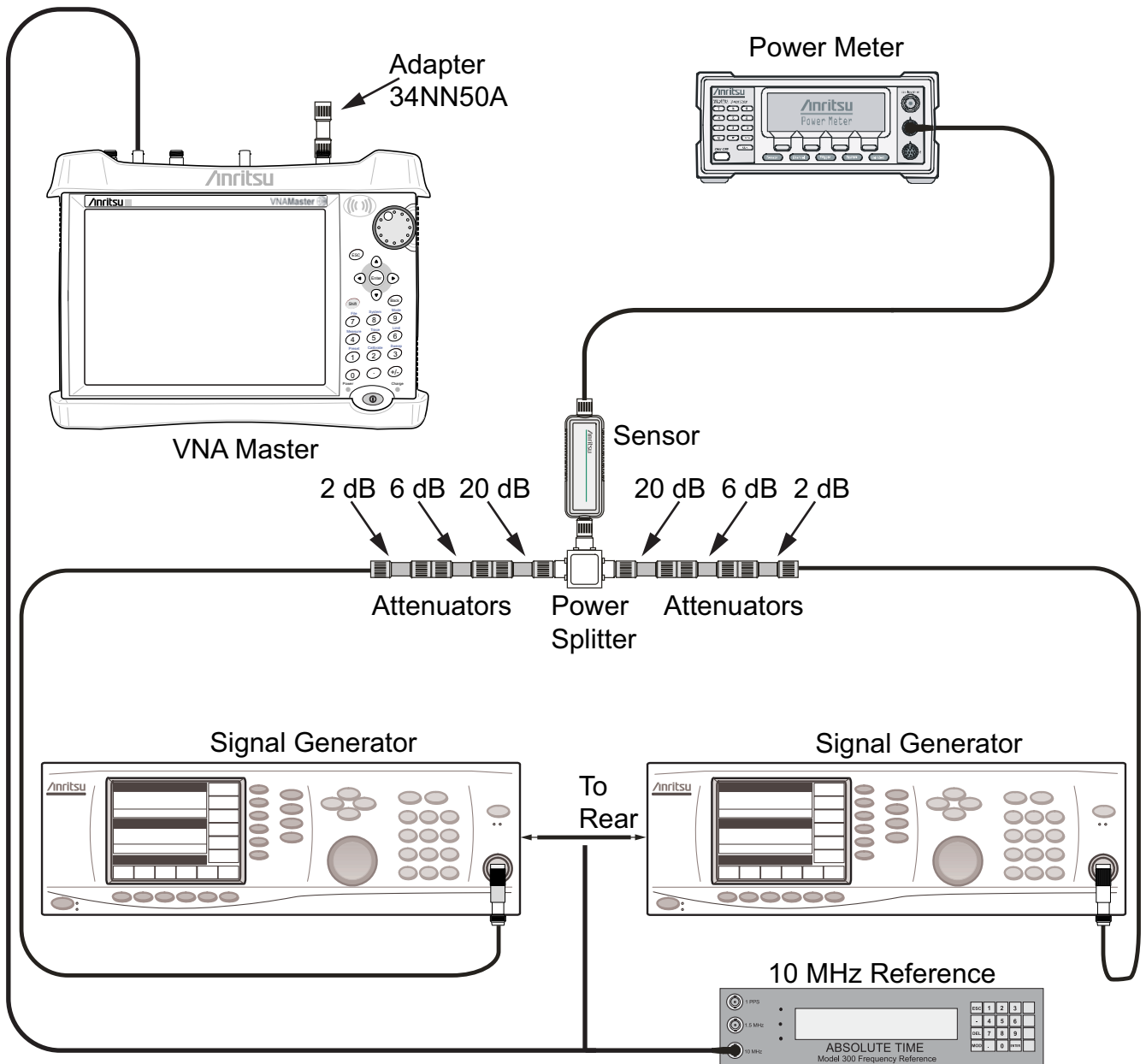

**Figure 3-8.** Third Order Intercept (TOI) Pre-test Setup

### 800 MHz TOI Test

2. Set the MG3692x Synthesized Signal Generator #1 to 799.951 MHz CW, and set the MG3692x Synthesized Signal Generator #2 to 800.051 MHz.
3. Turn Off the RF of the MG3692x Synthesized Signal Generator #1 and the MG3692x Synthesized Signal Generator #2.
4. On the ML2438A power meter, zero the sensor and set the calibration factor to 800 MHz.
5. Connect the power sensor to the power splitter output.
6. On the MG3692x Synthesized Signal Generator #1, turn the RF On, and adjust the RF amplitude so that  $-20$  dBm appears at the splitter output (approximately  $+16$  dBm).
7. Turn Off the RF of the MG3692x Synthesized Signal Generator #1.

8. On the MG3692x Synthesized Signal Generator #2, turn the RF On, and adjust the RF amplitude so that  $-20$  dBm appears at the splitter output (approximately  $+16$  dBm).
9. Turn Off the RF of the MG3692x Synthesized Signal Generator #2.
10. Set the MS203XB to Spectrum Analyzer mode and then Preset the instrument.
11. Press the **Shift** key, the **Sweep (3)** key, Sweep Mode submenu key and then the Performance submenu key.
12. Press the **Back** button and press the Detection submenu button and then the RMS/AVG submenu button.
13. Set the MS203xB as follows:
  - Center Frequency: 800.151 MHz
  - Span: 100 Hz
  - RBW: 30 Hz
  - VBW: 1 Hz
  - Reference Level:  $-15$  dBm
  - Atten Lvl: 0 dB
  - Preamp: Off



14. Disconnect the power sensor from the output of the power splitter and connect the power splitter output to the MS203XB RF In connector through the Anritsu Model 34NN50A adapter as shown in [Figure 3-9](#).

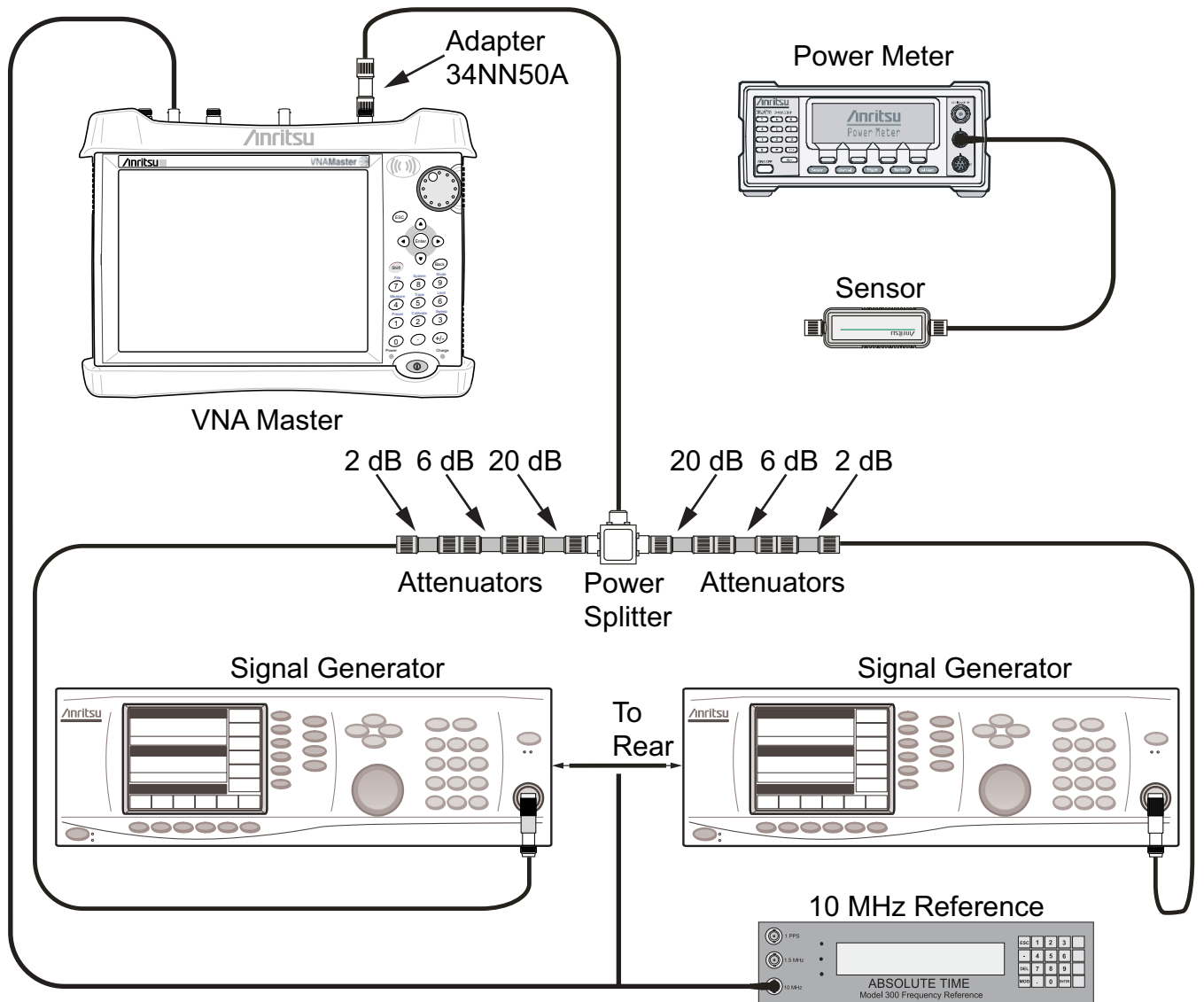

**Figure 3-9.** Third Order Intercept (TOI) Measurement Setup

15. Turn On the RF of both MG3692x #1 and MG3692x #2.
16. On the MS203XB, press the **Shift** key and then the **Trace (5)** key. Press Trace A Operations, and set # of Averages to 2.
17. After two sweeps have occurred (Trace Count 2/2 appears on the left of the display), turn on a marker, and press Peak Search. Record the amplitude of the signal at 800.151 MHz in [Table A-21](#) for MS2034B or [Table A-38](#) for MS2035B in [Appendix A](#).
18. Change the Center Frequency of the MS203XB to 799.851 MHz.
19. After two sweeps have occurred (Trace Count 2/2 appears on the left of the display), turn on a marker, and press Peak Search. Record the amplitude of this signal in the following tables in [Appendix A](#).
  - MS2034B – [Table A-29](#), “Spectrum Analyzer Third Order Intercept” on page A-14
  - MS2035B – [Table A-56](#), “Spectrum Analyzer Third Order Intercept” on page A-28

20. Determine which signal is larger (the 799.851 MHz signal or the 800.151 MHz signal). Use the larger value for max in the following formula to calculate the TOI for 800 MHz (refer to the example calculation below the formula):

$$\text{TOI} = -20 + [(-20 - \text{max}) / 2] + 10 \text{ dBm}$$

Example: Assume max = -72 dBm

$$\text{Then: TOI} = -20 + [(-20 - (-72))/2] + 10 = +16 \text{ dBm}$$

21. Record the calculated 800 MHz TOI measurement in [Table A-21](#) for MS2034B or [Table A-38](#) for MS2035B in [Appendix A](#).
22. Turn Off the RF of the MG3692x Synthesized Signal Generator #1 and the MG3692x Synthesized Signal Generator #2.

### 2400 MHz TOI Test

23. Disconnect the power splitter from the MS203XB.
24. Set the MG3692x Synthesized Signal Generator #1 to 2399.951 MHz CW, and set the MG3692x Synthesized Signal Generator #2 to 2400.051 MHz.
25. On the ML2438A power meter, set the calibration factor to 2.4 GHz.
26. Connect the power sensor to the power splitter output. Refer to [Figure 3-8](#).
27. Set the MG3692x Synthesized Signal Generator #1 RF to On and adjust the RF amplitude so that -20 dBm appears at the power splitter output (approximately +16 dBm).
28. Turn Off the RF of the MG3692x Synthesized Signal Generator #1.
29. On the MG3692x Synthesized Signal Generator #2, turn the RF On, and adjust the RF amplitude so that -20 dBm appears at the splitter output (approximately +16 dBm).
30. Turn Off the RF of the MG3692x Synthesized Signal Generator #2.
31. Disconnect the power sensor from the output of the power splitter and connect the power splitter output to the MS203XB RF In connector through the Anritsu Model 34NN50A adapter. Refer to [Figure 3-9](#).
32. Turn On the RF of both MG3692x #1 and MG3692x #2.
33. Set the MS203XB Center Frequency to 2400.151 MHz.
34. Press the **Shift** key and then the **Trace (5)** key. Press Trace A Operations, and set # of Averages to 2.
35. After two sweeps have occurred (Trace Count 2/2 appears on the left of the display), turn on a marker, and press Peak Search. Record the amplitude of the signal at 2400.151 MHz in [Table A-21](#) for MS2034B or [Table A-38](#) for MS2035B in [Appendix A](#).
36. Change the Center Frequency of the MS203XB to 2399.851 MHz.
37. After two sweeps have occurred (Trace Count 2/2 appears on the left of the display), turn on a marker, and press Peak Search. Record the amplitude of this signal in [Table A-21](#) for MS2034B or [Table A-38](#) for MS2035B in [Appendix A](#).
38. Determine which signal is larger (the 2399.851 MHz signal or the 2400.151 MHz signal). Use the larger value for max in the following formula to calculate the TOI for 2400 MHz (refer to the example calculation below the formula):
- $$\text{TOI} = -20 + [(-20 - \text{max}) / 2] + 10 \text{ dBm}$$
- Example: Assume max = -80 dBm
- $$\text{Then: TOI} = -20 + [(-20 - (-80))/2] + 10 = +20 \text{ dBm}$$
39. Record the calculated 2400 MHz TOI measurement in [Table A-21](#) for MS2034B or [Table A-38](#) for MS2035B in [Appendix A](#).
40. Turn Off the RF of both MG3692x #1 and MG3692x #2.

# Chapter 4 — Options Performance Verification

## 4-1 Introduction

This chapter contains tests that are used to verify the performance of options that are installed in VNA Master Models MS2024B, MS2025B, MS2034B, and MS2035B. Blank performance verification test records are provided in [Appendix A](#). Make a copy of the blank test records and use them to record measured values.

The test procedures are as follows:

- [“VNA Mode Bias Tee \(Option 10\) Operational Check” on page 4-2](#)
- [“GPS \(Option 31\) Operational Check” on page 4-4](#)
- [“Spectrum Analyzer Frequency Accuracy with GPS On” on page 4-6](#)

<b>Caution</b> Verify that all equipment has warmed up for at least 30 minutes before making any measurements.
--

## 4-2 VNA Mode Bias Tee (Option 10) Operational Check

If the Bias Tee (Option 10) is installed in the VNA Master, then the following test can be used to verify the internal bias tee functionality in the Vector Network Analyzer Mode of MS2024B, MS2025B, MS2034B and MS2035B.

### Equipment Required

- Calibration Tee, N male, Anritsu Model OSLN50-1
- 78 ohm, 1 Watt, Low Current Load, Anritsu part number T3536
- 105 ohm, 1 Watt, Low Current Load, Anritsu part number T3377
- AC Power Adapter, Anritsu part number 40-168-R

### Procedure

1. Connect the AC Power Adapter (Anritsu part number 40-168-R) to the VNA Master and then plug the power cord of the AC Power Adapter to an AC outlet.

<b>Note</b>	The VNA Master must be powered by external AC power for this test.
-------------	--

2. Press the **On/Off** key to turn on the VNA Master.
3. Press the **Shift** key and then the **Preset (1)** key. Press the **Preset** button on the touch screen submenu to set the instrument to the factory preset state.

<b>Note</b>	Before continuing, allow a 30-minute warm up for the internal circuitry to stabilize.
-------------	---

4. Press the **Freq/Dist** button on the touch screen main menu. Then press the **Start Freq** submenu button.
5. Use the numeric keypad to enter **2** and then press the **MHz** submenu button to set the Start Frequency to 2 MHz
6. Press the **Measure** main menu button and then press the **Number of Traces** submenu button. Select **1**.
7. Press the **Maximize Active Trace** submenu button.
8. Press the **Graph Type** submenu button. Use the rotary knob to highlight **Log Mag** and press the **Enter** key to select it.
9. Press the **S Parameter** submenu button. Select **S21**.
10. Press the **Sweep** main menu button.
11. Press the **Configure Ports** submenu button and then press **Bias Tee Setup**.

#### Voltage and Current Test

12. Connect the 105 ohm Load to **VNA Port 2** connector of the VNA Master.
13. Ensure that the **Int Voltage P2** setting is **12.0 V**.
14. Press the **Bias Tee** submenu button and then press the **On** submenu button to turn the Bias Tee On.
15. Verify the voltage and current readings displayed on the upper left corner of the screen are within the range shown in [Table 4-1, "VNA Bias Tee Verification"](#).

**Table 4-1.** VNA Bias Tee Verification

Voltage Setting (V)	12.0	18.0	32.0
Expected Voltage (V)	10.8 to 13.2	16.2 to 19.8	28.8 to 35.2

Table 4-1. VNA Bias Tee Verification

Voltage Setting (V)	12.0	18.0	32.0
Expected Current (mA)	85 to 145	142 to 202	370 to 450

16. Press the **Off** submenu button to turn the Bias Tee Off. Press the **Back** submenu button to return to previous menu.
17. Press the **Int Voltage P2** submenu button. Use the numeric keypad to enter **18** and then press the **V** submenu button to change the voltage to 18.0 V.
18. Repeat Step 14 through Step 16.
19. Remove the 105 ohm Load from **VNA Port 2** and connect the 78 ohm Load to **VNA Port 2**.
20. Press the **Int Voltage P2** submenu button. Use the numeric keypad to enter **32** and then press the **V** submenu button to change the voltage to 32.0 V.
21. Repeat Step 14 through Step 16.
22. Remove the 78 ohm Load from **VNA Port 2**.

#### Fault Test

23. Connect the Short of the Calibration Tee to **VNA Port 2**.
24. Change Int Voltage P2 to 12.0 V.
25. Press the **Bias Tee** submenu button and then press the **On** submenu button to turn the Bias Tee On.
26. Verify that the instrument displays the Bias Tee voltage and current reading in the upper left corner of the screen is flashing 0.0 V and 0 mA.
27. Press the **Off** submenu button to turn off the Bias Tee.

## 4-3 GPS (Option 31) Operational Check

The following test is used to verify the operation of the GPS option for MS2024B, MS2025B, MS2034B and MS2035B.

### Equipment Required

- SMA(m) to BNC(f) Adapter, Pomona part number 4290
- BNC(m) 93 ohm Terminator, Amphenol part number B1004A1-ND3G-93R-0.05-1W
- GPS Antenna, Anritsu part number 2000-1528-R or Trimble part number 57861-00
- AC Power Adapter, Anritsu part number 40-168-R

### Procedure

1. Connect the SMA(m) to BNC(f) Adapter to the **GPS** connector of the VNA Master.
2. Connect the BNC(m) 93 ohm terminator to the BNC(f) end of the adapter.
3. Connect the external AC Power Adapter (Anritsu part number 40-168-R) to the VNA Master and then plug the power cord of the AC Power Adapter to an AC outlet.

<b>Note</b>	The VNA Master must be powered by external AC power for this test.
-------------	--

4. Press the **On/Off** key to turn on the VNA Master.
5. Press the **Shift** key and then the **Preset (1)** key. Press the Preset button on the touch screen submenu to set the instrument to the factory preset state.

<b>Note</b>	Before continuing, allow a 30-minute warm up for the internal circuitry to stabilize.
-------------	---

6. Press the **Shift** key and then the **System (8)** key.
7. Press the GPS submenu button.

#### GPS Antenna Bias Tee Operational Check

8. Confirm that the 3.3 V setting on the GPS Voltage submenu button is selected (underlined).
9. Press the GPS On/Off submenu button to turn On GPS feature.
10. Press the GPS Info submenu button and wait until the GPS INFO dialog box appears.
11. Verify that the GPS Antenna Current is within the expected current range for 3.3 V Bias per [Table 4-2, "Option 31 GPS Antenna Bias Tee Operational Check"](#).

**Table 4-2.** Option 31 GPS Antenna Bias Tee Operational Check

Voltage Setting	Expected Current Range
3.3 V	27 mA – 38 mA
5 V	42 mA – 64 mA

12. Press the **Esc** key to dismiss the GPS INFO dialog box.
13. Press the GPS Voltage submenu button to select 5 V.
14. Press the GPS Info submenu button and wait until the GPS INFO dialog box appears.
15. Verify that the GPS Antenna Current is within the expected current range for 5 V Bias per Table 4-2.
16. Press the **Esc** key to dismiss the GPS INFO dialog box.
17. Press the GPS On/Off submenu button to turn off the GPS feature.

18. Remove the adapter and terminator from the GPS connector of the VNA Master.

**Note** For MS2034B and MS2035B, go to Section [Section 4-4 “Spectrum Analyzer Frequency Accuracy with GPS On”](#).

**GPS Receiver Operational Check (For MS2024B and MS2025B Only)**

19. Connect the GPS Antenna to the **GPS** connector of the VNA Master.

**Note** Ensure that the Anritsu GPS Antenna is in a direct line-of-sight relationship to the GPS satellites or the Antenna is placed outside without any obstructions.

20. Press the GPS On/Off submenu button to turn on the GPS feature.

**Note** Acquiring satellites may take as long as three minutes. The GPS indicator will turn green after at least three satellites has been tracked by the GPS receiver.

21. Verify that GPS indicator does turn green, which indicates the GPS receiver of the VNA Master can acquire satellite signals.

22. Press the GPS On/Off submenu button to turn on the GPS feature.

## 4-4 Spectrum Analyzer Frequency Accuracy with GPS On

The following test is used to verify the frequency accuracy of the spectrum analyzer with GPS On for MS2034B and MS2035B.

### Equipment Required

- GPS Antenna, Anritsu part number 2000-1528-R or Trimble part number 57861-00
- Synthesized Signal Generator, Anritsu Model MG3692X series
- K(m) to N(f) Adapter, Anritsu Model 34RKNF50
- 10 MHz Reference Standard
- RF Coaxial Cable, Anritsu Model 15NN50-1.5C
- BNC(m) to BNC(m) Coaxial Cable, Anritsu part number 2000-1627-R

### Procedure

1. Connect GPS Antenna to the GPS Antenna connector of the MS203XB VNA Master.

<b>Note</b>	Ensure that the Anritsu GPS Antenna is in a direct line-of-sight relationship to the GPS satellites or the Antenna is placed outside without any obstructions.
-------------	--

2. Connect BNC Coaxial Cable between the 10 MHz Reference Standard output and the 10 MHz Ref In connector of the Anritsu MG3692X Synthesized Signal Generator.

<b>Note</b>	Do not connect the external 10 MHz Reference to the VNA Master.
-------------	---



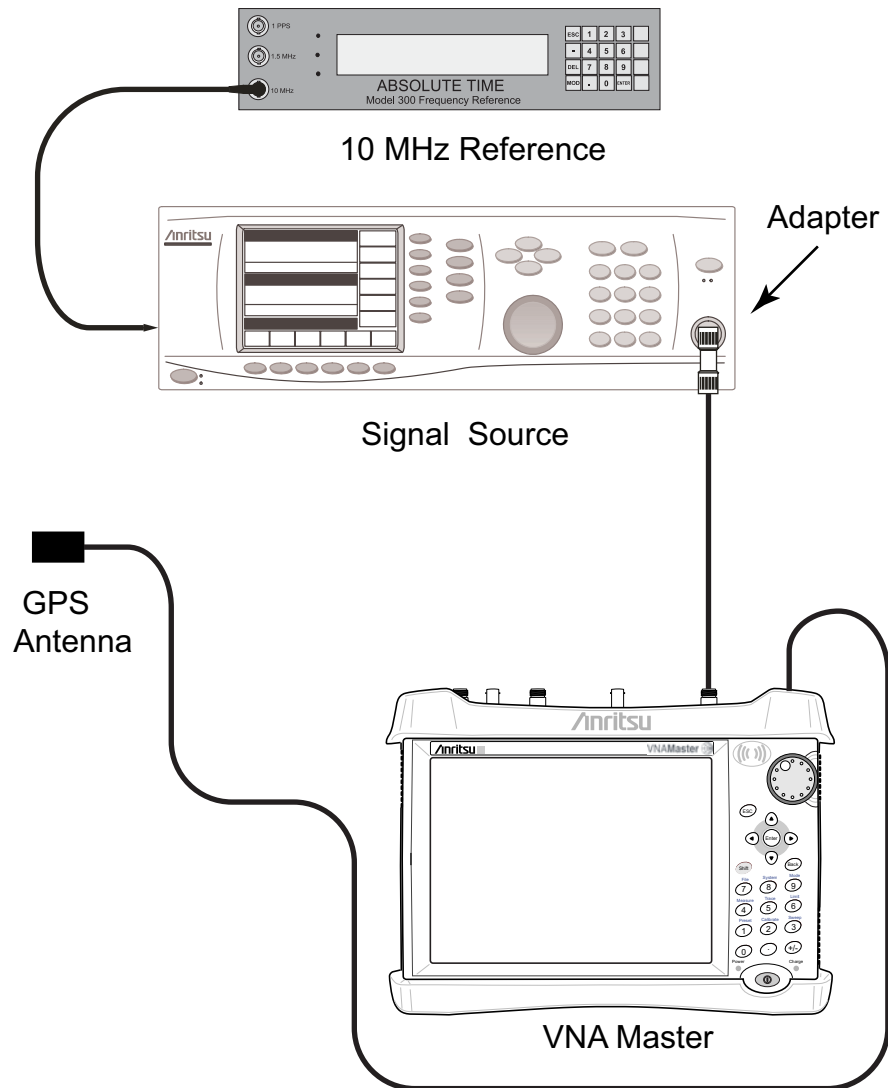

**Figure 4-1.** Spectrum Analyzer Frequency Accuracy with GPS On

3. Turn on both the 10 MHz Reference Standard and the Synthesized Signal Generator.
4. Set the MG3692X output to 3.9 GHz CW for MS2034B or to 5.9 GHz CW for MS2035B, with an RF output level of  $-30$  dBm.
5. Install the 34RKNF50 Adapter to the output of the MG3692X Generator and connect the 15NN50-1.5C RF Coaxial Cable between the Adapter and the RF In connector of the VNA Master.
6. Press the **On/Off** key to turn on the VNA Master.
7. Press the **Shift** key and then the **Mode (9)** key. Use the rotary knob to highlight Spectrum Analyzer and then press the **Enter** key to switch to Spectrum Analyzer mode.
8. Press the **Shift** key and then the **Preset (1)** key. Press the Preset button on the touch screen submenu to set the instrument to the factory preset state.
9. Press the **Amplitude** button on the touch screen main menu and then the Reference Level button on the touch screen submenu.
10. Use the numeric keypad to enter  $-10$  and press the dBm submenu button.
11. Press the Span submenu button.
12. Use the numeric keypad to enter 10 and then press the kHz submenu button.

13. Press the **BW** main menu button and then the RBW submenu button.
14. Use the numeric keypad to enter 100 and then press the HZ submenu button.
15. Press the VBW submenu button.
16. Use the numeric keypad to enter 30 and then press the HZ submenu button.
17. Press the **Freq** main menu button and then the Center Freq submenu button.
18. Use the numeric keypad to enter 3.9 (for MS2034B) or 5.9 (for MS2035B) and then press the GHz submenu button.
19. Press the **Shift** key and then the **System (8)** key.
20. Press the GPS submenu button.
21. Press the GPS On/Off submenu button to turn on the GPS feature.

<b>Note</b>	Acquiring satellites may take as long as three minutes. The GPS indicator will turn green after at least three satellites has been tracked by the GPS receiver.
-------------	---

22. Wait until the Reference Source has changed to “GPS Hi Accy” on the lower left hand corner of the display.
23. Press the **Marker** main menu button and then the **More** submenu button.
24. Set Counter Marker to On, press the **Back** submenu button, and then press the **Peak Search** submenu button.

<b>Note</b>	Without the Counter Marker On, the frequency resolution will not allow looking at the kHz accuracy.
-------------	---

25. Verify that the marker frequency reading is within specification and record the measured value in
26. [Table A-12](#) for MS2034B or [Table A-29](#) for MS2035B in [Appendix A](#).

<b>Note</b>	If the instrument fails this test, then contact your local Anritsu Service Center ( <a href="http://www.anritsu.com/Contact.asp">http://www.anritsu.com/Contact.asp</a> ).
-------------	--

# Chapter 5 — Battery Information

## 5-1 Introduction

This chapter describes battery information for VNA Master Models MS2024B, MS2025B, MS2034B, and MS2035B.

**Note**

Some of the procedures in this section are generic, and apply to many similar instruments. Photos and illustrations are representative and may show instruments other than the MS2024B, MS2025B, MS2034B, and MS2035B.

## 5-2 Battery Pack Removal and Replacement

This section provides instructions for the removing and replacing the battery pack.

1. With the instrument standing upright on its base and standing on a stable surface, locate the battery access door, as illustrated in [Figure 5-1](#).



**Figure 5-1.** Battery Access Door

2. Place a finger on the actuator in the recess at the top of the battery access door and press downward toward the bottom of the instrument and also outward. The door must be moved against spring pressure in order to release the upper catch.
3. Remove the battery access door.
4. With the battery access door completely removed, grasp the flexible handle of the battery and pull the battery straight out of the instrument (refer to [Figure 5-2 on page 5-3](#)).
5. Replacement is the opposite of removal. Note the orientation of the battery contacts (refer to [Figure 5-3 on page 5-3](#)), and be sure to insert the new battery with the contacts facing the bottom of the instrument.



Figure 5-2. Battery Insertion and Removal

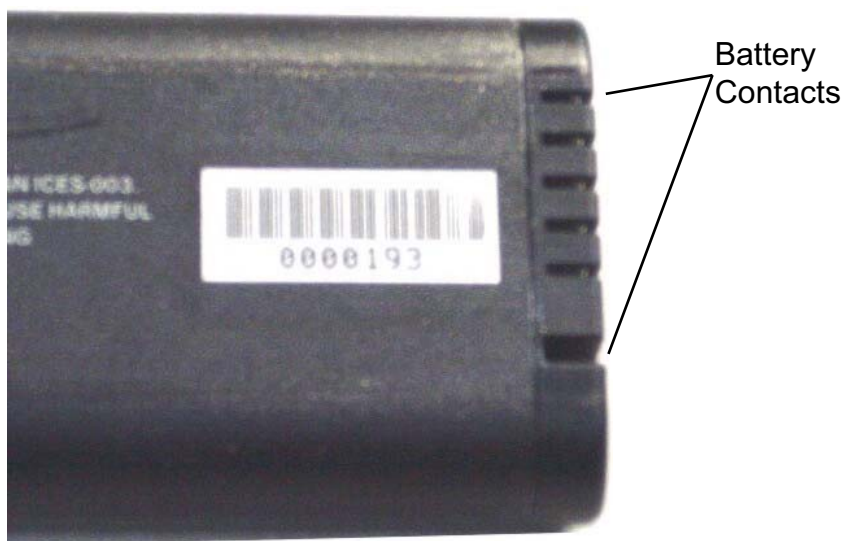

Figure 5-3. Battery Contacts

## Battery Pack Information

The following information relates to the care and handling of the Anritsu 633-44 battery pack and Lithium-Ion batteries in general.

- The 633-44 battery pack that is supplied with your instrument may need charging before use. Before using the VNA Master, the internal battery may be charged in the VNA Master, using either the AC-DC Adapter (40-168) or the 12 Volt DC adapter (806-141), or may be charged separately in the optional Dual Battery Charger (2000-1374).
- Use only Anritsu approved battery packs. Some non-approved battery packs will fit into the VNA Master, but are electrically incompatible and will not charge correctly.
- Recharge the battery only in the VNA Master or in an Anritsu approved charger.
- When the VNA Master or the charger is not in use, disconnect it from the power source.
- Do not charge batteries for longer than 24 hours. Overcharging may shorten battery life.
- If left unused, a fully charged battery will discharge itself over time.
- Temperature extremes affect the ability of the battery to charge. Allow the battery to cool down or warm up as necessary before use or charging.
- Discharge the battery from time to time in order to improve battery performance and battery life.
- The battery can be charged and discharged hundreds of times, but it will eventually wear out.
- The battery may need to be replaced when the operating time between chargings becomes noticeably shorter than normal.
- Never use a damaged or worn out charger or battery.
- Storing the battery in extremely hot or cold places will reduce the capacity and lifetime of the battery.
- Never short-circuit the battery terminals.
- Do not drop, mutilate, or attempt to disassemble the battery.
- Do not dispose of batteries in a fire!
- Batteries must be recycled or disposed of properly. Do not place batteries in household garbage.
- Always use the battery for its intended purpose only.

# Chapter 6 — Removal and Replacement

## 6-1 Introduction

This chapter describes the removal and replacement procedures for the various assemblies of VNA Master Models MS2024B, MS2025B, MS2034B, and MS2035B. Illustrations (drawings or photographs) in this manual may differ slightly from the instrument that you are servicing, but the basic removal and replacement functions will remain as specified. The illustrations are meant to provide assistance with identifying parts and their locations.

<b>Note</b>	Some of the procedures in this section are generic, and apply to many similar instruments. Photos and illustrations are representative and may show instruments other than the MS2024B, MS2025B, MS2034B, and MS2035B.
-------------	--

The Main/VNA PCB Assembly for MS202xB instruments, and the Main/VNA/DSP PCB Assembly for MS203xB instruments may also be described as the Mother Board. In all four VNA Master Models, the VNA circuitry is on the Mother Board: ND72051, ND72052, ND72117, and ND72118. The complete list of replaceable parts is documented in [Table 1-7 on page 1-8](#).

## Figures of Instrument Construction

The figures at the beginning of this chapter reveal the inner construction of the VNA Master instruments.

- [“Internal Anatomy of All Four VNA Master Models” on page 6-3](#)
  - [“First Step for Opening the Case” on page 6-3](#)
  - [“Screws on Case Back” on page 6-4](#)
  - [“Basic Case Parts” on page 6-5](#)
  - [“MS20xxB Instrument Overview” on page 6-6](#)
- [“Internal Anatomy of MS202xB” on page 6-7](#)
  - [“MS202xB Separating Case Back from Case Front” on page 6-7](#)
  - [“MS202xB Parts in Case Front” on page 6-8](#)
  - [“MS202xB Connector Panel” on page 6-9](#)
- [“Internal Anatomy of MS203xB” on page 6-10](#)
  - [“MS203xB Separating Case Back from Case Front” on page 6-10](#)
  - [“MS203xB Parts in Case Front” on page 6-11](#)
  - [“MS203xB Connector Panel” on page 6-12](#)
  - [“PCB Assembly Out Of Case” on page 6-20](#)
  - [“PCB Cable connections” on page 6-22](#)
  - [“Ethernet PCB Assembly” on page 6-27](#)

## Removal And Replacement Instructions

The removal and replacement instructions are described in the following sections:

- [Section 6-6 “Opening the Instrument Case” on page 6-14](#)
- [Section 6-7 “PCB Assembly Replacement \(MS202xB and MS203xB\)” on page 6-17](#)  
Section 6-7 is preliminary to the remaining sections,
- [Section 6-8 “SPA Assembly Replacement” on page 6-19](#)
- [Section 6-9 “GPS \(Option 31\) Replacement” on page 6-24](#)
- [Section 6-10 “Ethernet PCB Assembly \(Option 411\) Replacement” on page 6-26](#)
- [Section 6-11 “Main/VNA PCB Assembly Replacement” on page 6-28](#)
- [Section 6-12 “Main/VNA/DSP PCB Assembly Replacement” on page 6-29](#)
- [Section 6-13 “Fan Assembly Replacement” on page 6-30](#)
- [Section 6-14 “LCD Assembly Replacement” on page 6-32](#)
- [Section 6-15 “LCD Backlight PCB Removal and Replacement” on page 6-35](#)
- [Section 6-16 “Keypad and Keypad PCB Replacement” on page 6-36](#)
- [Section 6-17 “Touch Screen Replacement” on page 6-37](#)



## 6-2 Internal Anatomy of All Four VNA Master Models

### First Step for Opening the Case

---

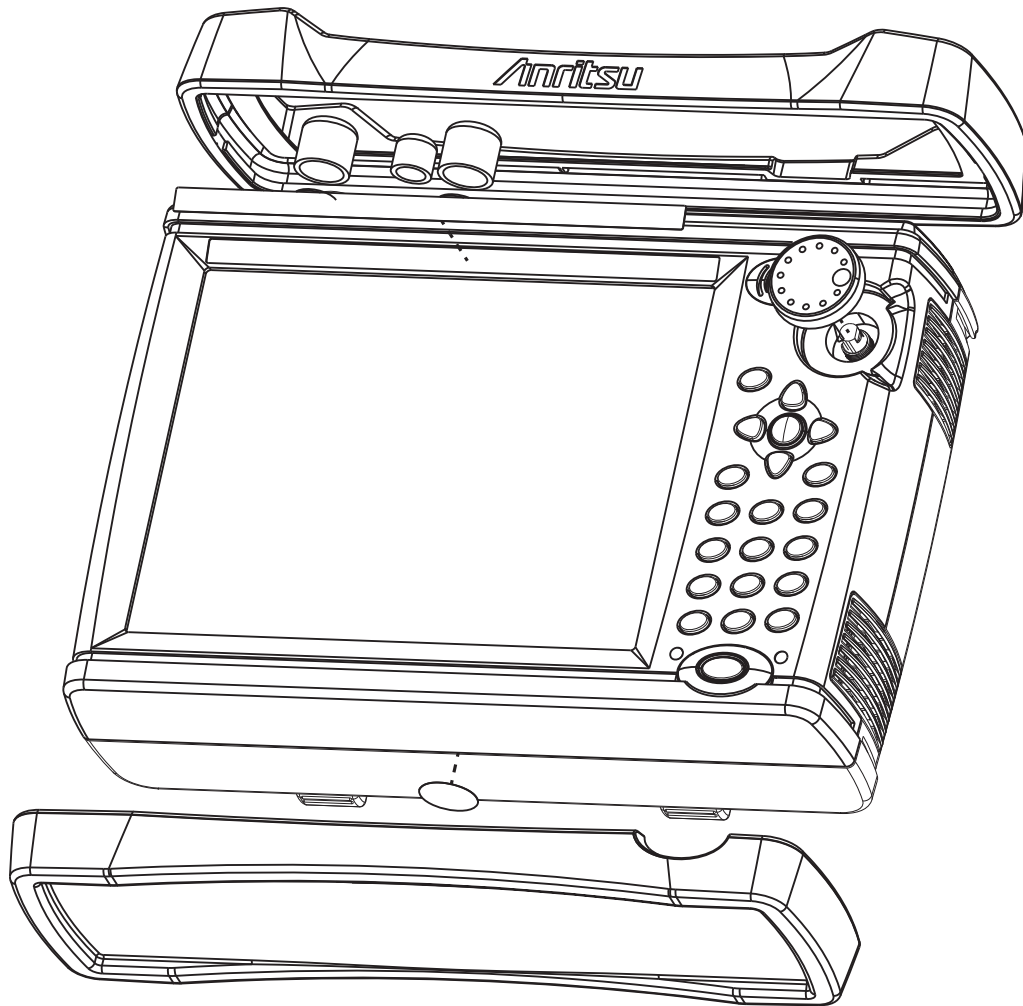

**Figure 6-1.** Removal of Bumpers and Rotary Knob

## Screws on Case Back

---



---

**Figure 6-2.** Location of Six Screws that Secure Case Back to Case Front

Figure 6-2 shows the 6 screw locations for opening the case (arrows) and also shows the 4 screws that secure the tilt bail.

## Basic Case Parts

---

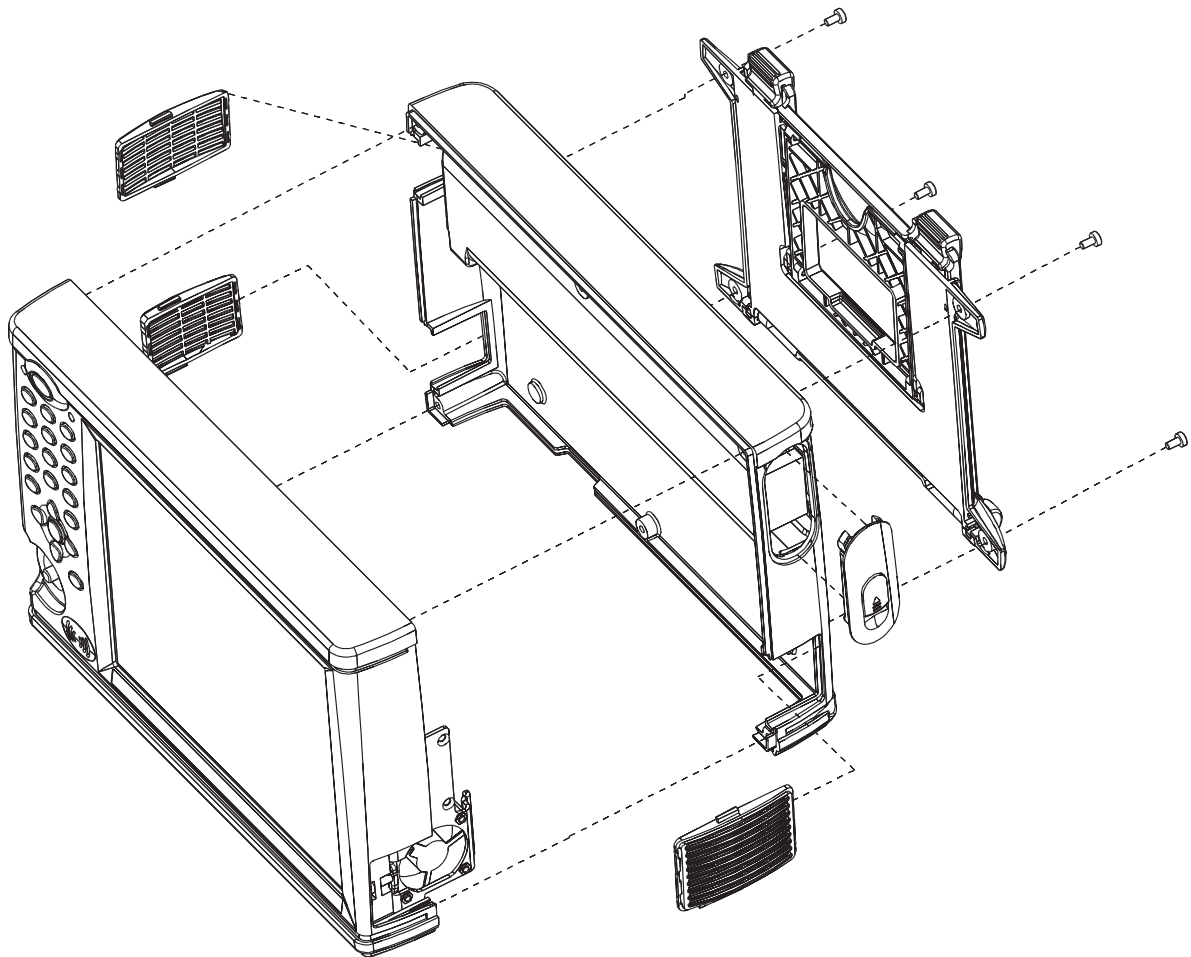

**Figure 6-3.** Perspective View of Case Parts (Case bottom is Facing Upward)

The Case Front includes the Keypad, Touch Screen, LCD, and Fan.

The Case Back includes the Battery Compartment and its Door.

[Figure 6-3](#) also shows the Tilt Bail and the 3 vents (ventilation grills) for Fan intake and exhaust.

## MS20xxB Instrument Overview



1. Touch Screen and LCD Display
2. Fan Inlet Vent
3. Top Bumper
4. Ventilation Exhaust Vent
5. Rotary Knob
6. Keypad
7. Ventilation Exhaust Vent
8. Bottom Bumper

**Figure 6-4.** Front View of MS2024B

## 6-3 Internal Anatomy of MS20xB

### MS20xB Separating Case Back from Case Front

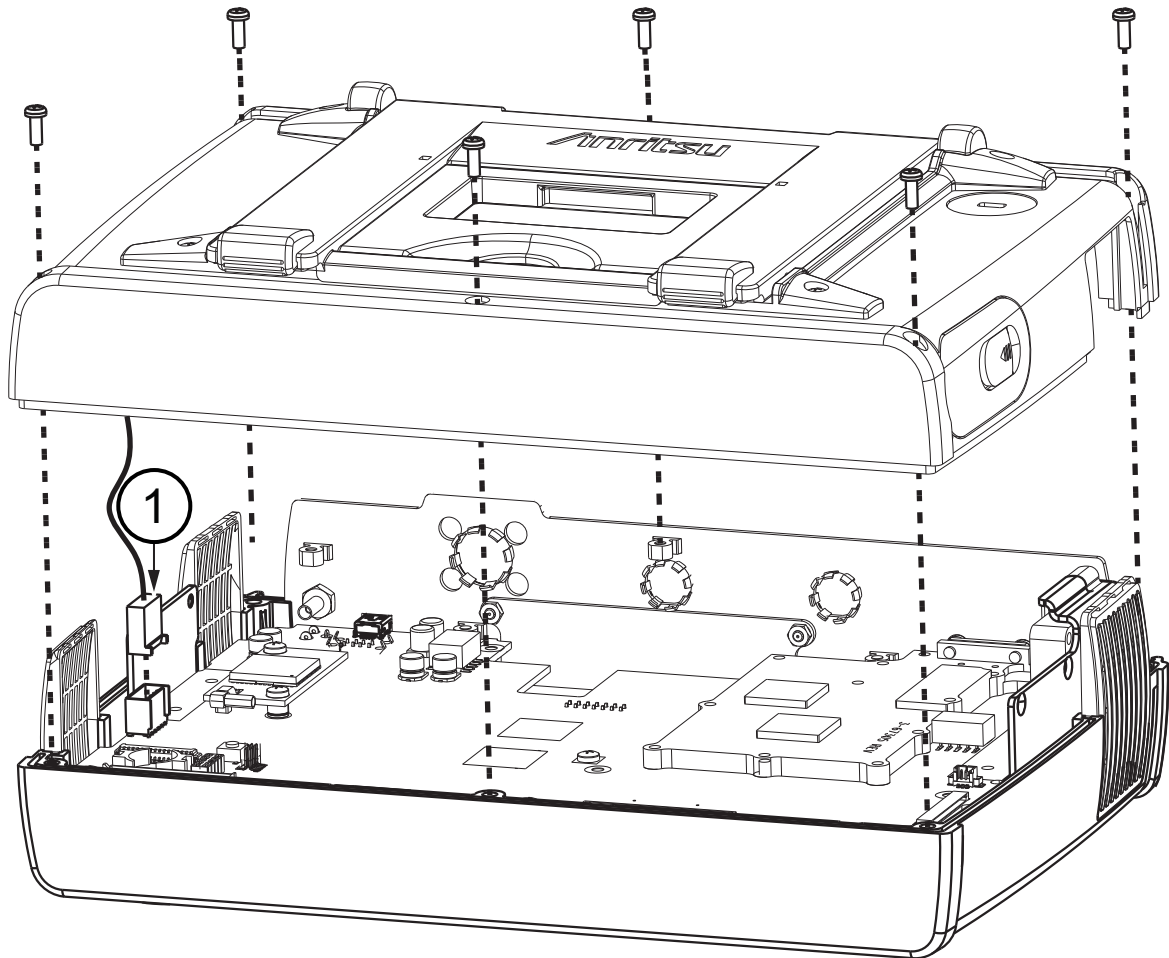

1. Battery Cable and Connection to Mother Board

**Figure 6-5.** Opening the Case

## MS202xB Parts in Case Front

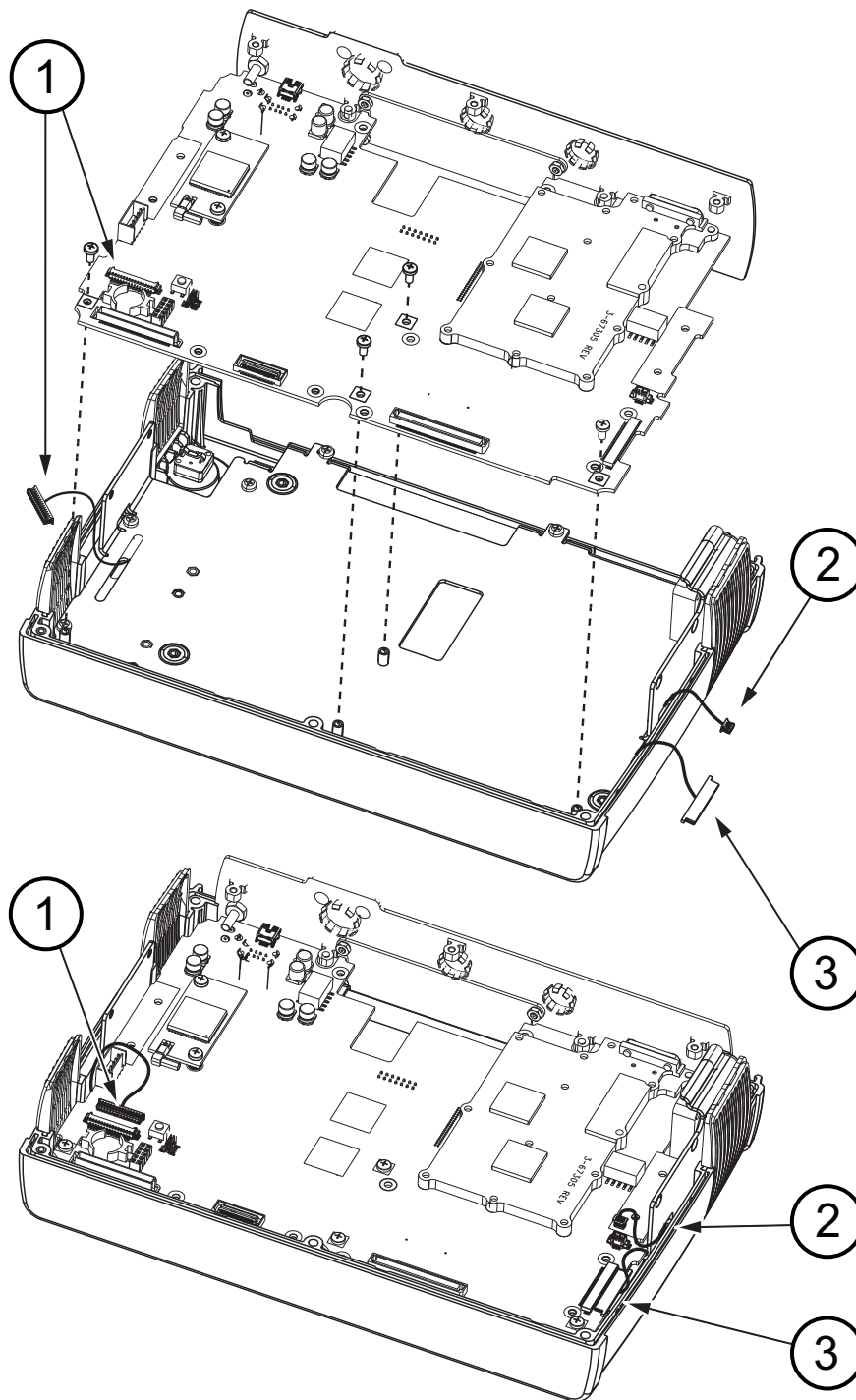

1. Keyboard Cable and Connector on Mother Board
2. Fan Cable and Connector Location
3. LCD Cable and Connector Location

**Figure 6-6.** Parts in Front Case

## MS202xB Connector Panel

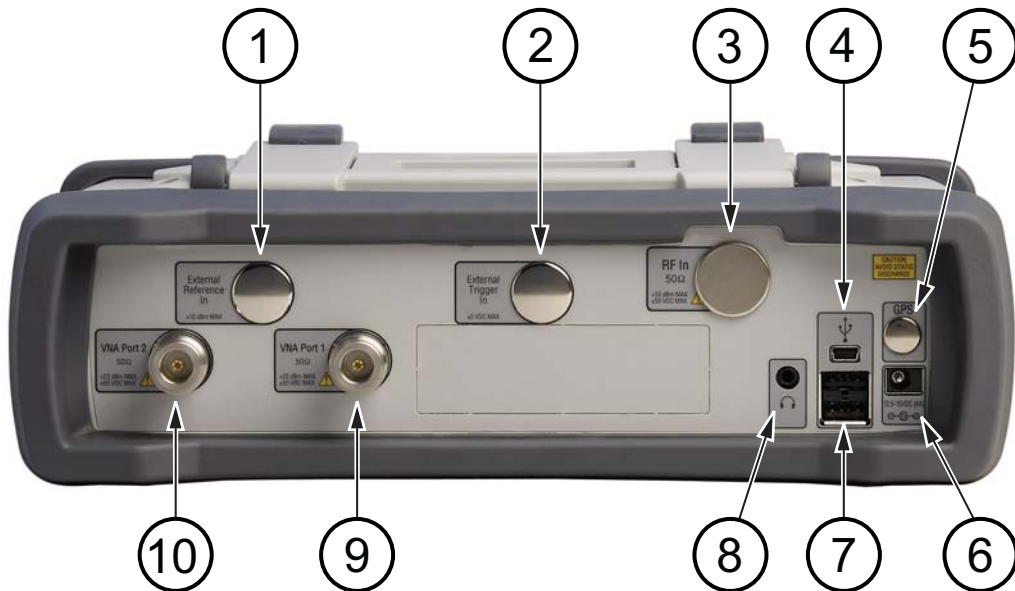

1. External Reference In (not installed in MS202xB models)
2. External Trigger In (not installed in MS202xB models)
3. RF In (not installed in MS202xB models)
4. USB Mini-B (Full Speed, USB 2.0)
5. GPS Antenna (location when installed with Option 31)
6. External Power
7. USB Type A (Full Speed, USB 2.0)
8. Headphone
9. VNA Port 1 50 ohm (Green LED indicates the Port is Transmitting Power)
10. VNA Port 2 50 ohm (Green LED indicates the Port is Transmitting Power)

**Figure 6-7.** MS202xB Connector Panel

## 6-4 Internal Anatomy of MS203xB

### MS203xB Separating Case Back from Case Front

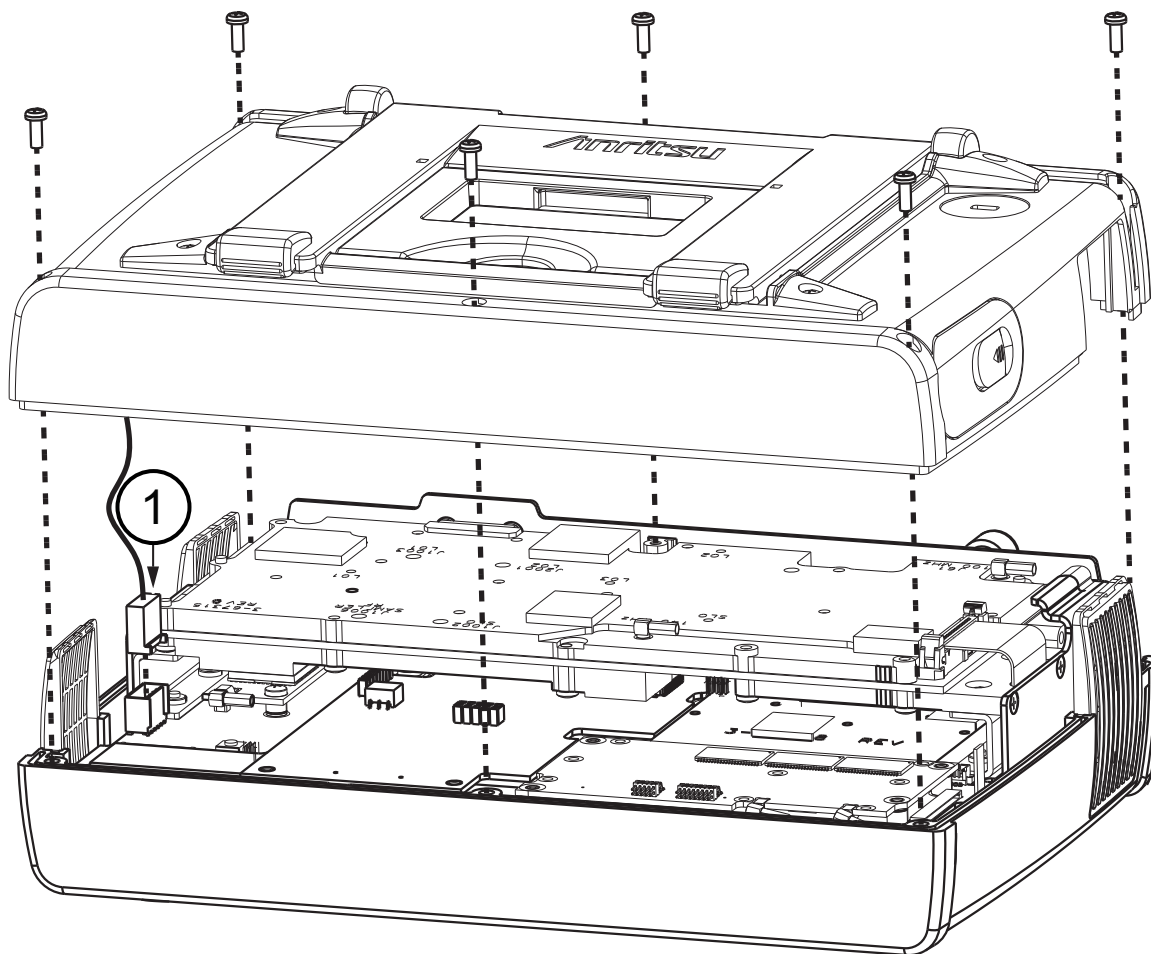

1. Battery Cable and Connection to Mother Board

**Figure 6-8.** Battery Cable and Connection to Mother Board

In addition to the basic parts within the MS202xB models, the MS203xB models contain a SPA PCB and DSP PCB, both attached to the Mother Board.



MS203xB Parts in Case Front

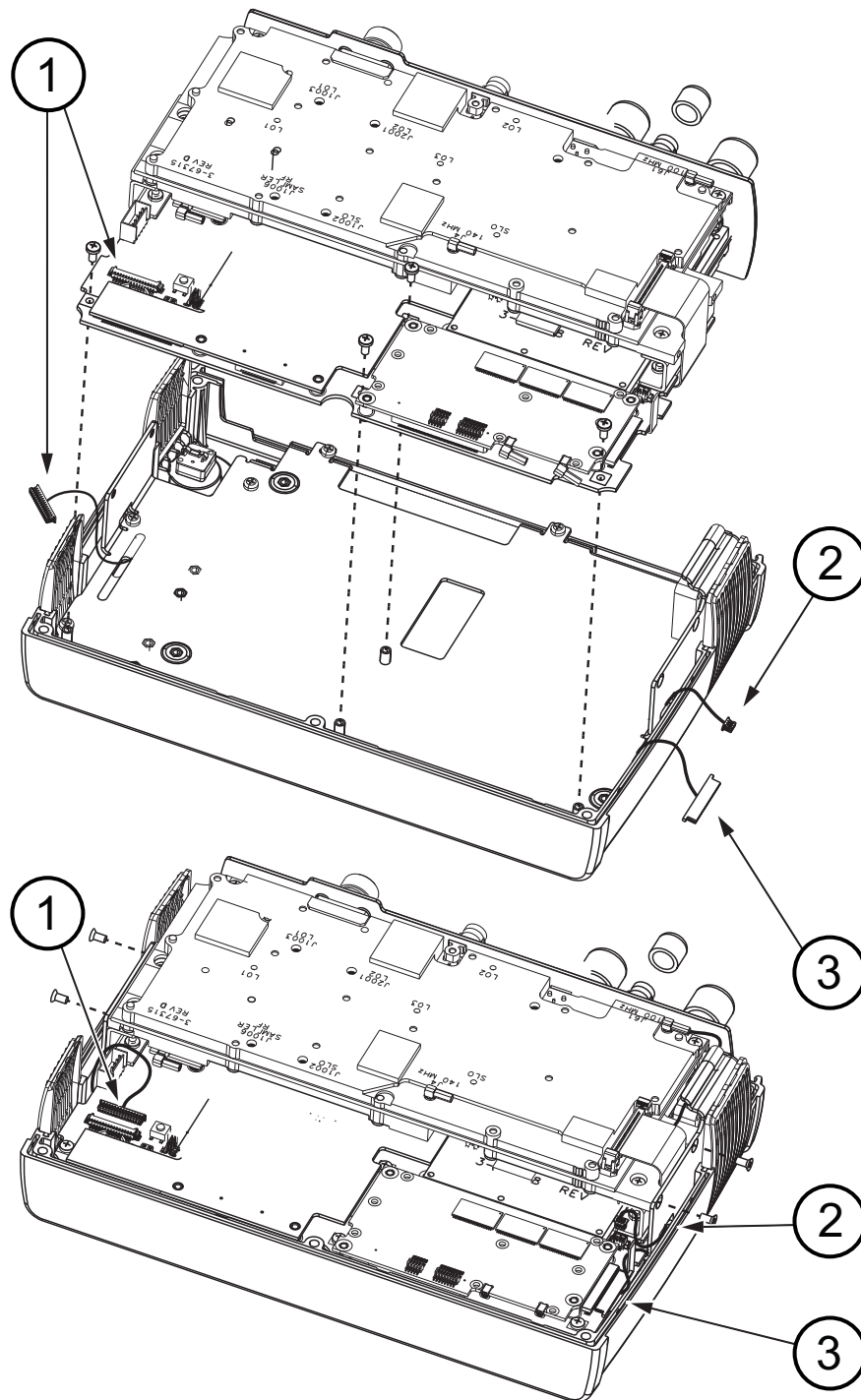

1. Keyboard Cable and Connector on Mother Board
2. Fan Cable and Connector Location
3. LCD Cable and Connector Location

Figure 6-9. Parts in Front Case

## MS203xB Connector Panel

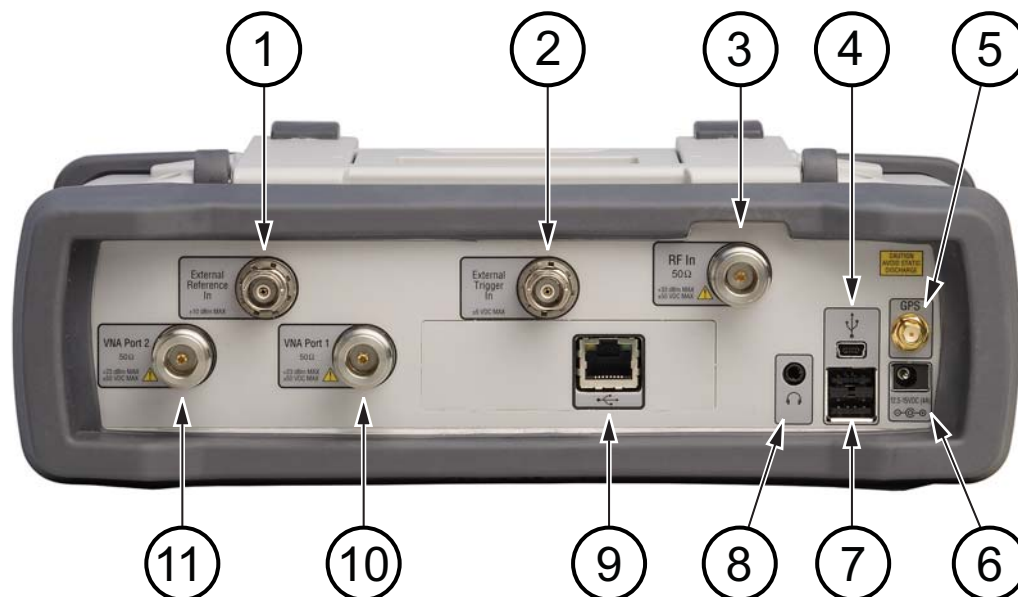

1. External Reference In
2. External Trigger In
3. RF In
4. USB Mini-B (Full Speed, USB 2.0)
5. GPS Antenna (with Option 31)
6. External Power
7. USB Type A (Full Speed, USB 2.0)
8. Headphone
9. Ethernet LAN Connector (with Option 411)
10. VNA Port 1 50 ohm (Green LED indicates the Port is Transmitting Power)
11. VNA Port 2 50 ohm (Green LED indicates the Port is Transmitting Power)

**Figure 6-10.** MS203xB Connector Panel

## 6-5 Disassembly Sequence Overview

Except for replacing the Rotary Knob, the case must be opened for all maintenance operations. Part numbers for all replaceable parts are found in [Table 1-7, “List of Replaceable Parts” on page 1-8](#).

**Caution**

Only qualified personnel should open the case and replace internal assemblies. Assemblies that are shown in the replaceable parts list are typically the only items that may be replaced.

Because they are highly fragile, items that must be soldered may not be replaced without specialized training.

Removing RF shields from PC boards, or adjusting screws on or near the shields may detune sensitive RF circuits and will result in degraded instrument performance.

All work must be performed in a static-safe work area.

**Note**

Before opening the case, Anritsu Company strongly recommends that all internally-saved files be saved to a PC by using the Master Software Tools utility program, or that they be copied to an external USB flash drive. In the event that the Main/VNA PCB needs to be replaced, this recommended action will prevent permanent loss of these files.

The figures at the beginning of this chapter reveal the inner construction of the VNA Master instruments. The removal and replacement instructions are described in the following sections:

- [Section 6-6 “Opening the Instrument Case” on page 6-14](#)
- [Section 6-7 “PCB Assembly Replacement \(MS202xB and MS203xB\)” on page 6-17](#)  
Section 6-7 is preliminary to the remaining sections,
- [Section 6-8 “SPA Assembly Replacement” on page 6-19](#)
- [Section 6-9 “GPS \(Option 31\) Replacement” on page 6-24](#)
- [Section 6-10 “Ethernet PCB Assembly \(Option 411\) Replacement” on page 6-26](#)
- [Section 6-11 “Main/VNA PCB Assembly Replacement” on page 6-28](#)
- [Section 6-12 “Main/VNA/DSP PCB Assembly Replacement” on page 6-29](#)
- [Section 6-13 “Fan Assembly Replacement” on page 6-30](#)
- [Section 6-14 “LCD Assembly Replacement” on page 6-32](#)
- [Section 6-15 “LCD Backlight PCB Removal and Replacement” on page 6-35](#)
- [Section 6-16 “Keypad and Keypad PCB Replacement” on page 6-36](#)
- [Section 6-17 “Touch Screen Replacement” on page 6-37](#)

## 6-6 Opening the Instrument Case

This procedure provides instructions for opening the VNA Master case. With the case opened, the internal assemblies can be removed and replaced, as described in the rest of this chapter.

**Caution**

Electrostatic Discharge (ESD) can damage the highly sensitive circuits in the instrument.

Repair of damage that is found to be caused by electrostatic discharge is not covered under warranty.

The VNA Master contains components that can be easily damaged by electrostatic discharge (ESD). An ESD safe work area and proper ESD handling procedures that conform to ANSI/ESD S20.20-1999 or ANSI/ESD S20.20-2007 are mandatory to avoid ESD damage when handling subassemblies or components that are found in these instruments.

**Procedure:**

1. Remove the battery door and battery as shown in [Section 4-4 “Spectrum Analyzer Frequency Accuracy with GPS On”](#) on page 4-6.
2. Remove the top and bottom bumpers ([Figure 6-11](#)) to expose the screw holes on the back of the unit. Pull on a corner of each rubber bumper to stretch and disengage the rubber from the case.

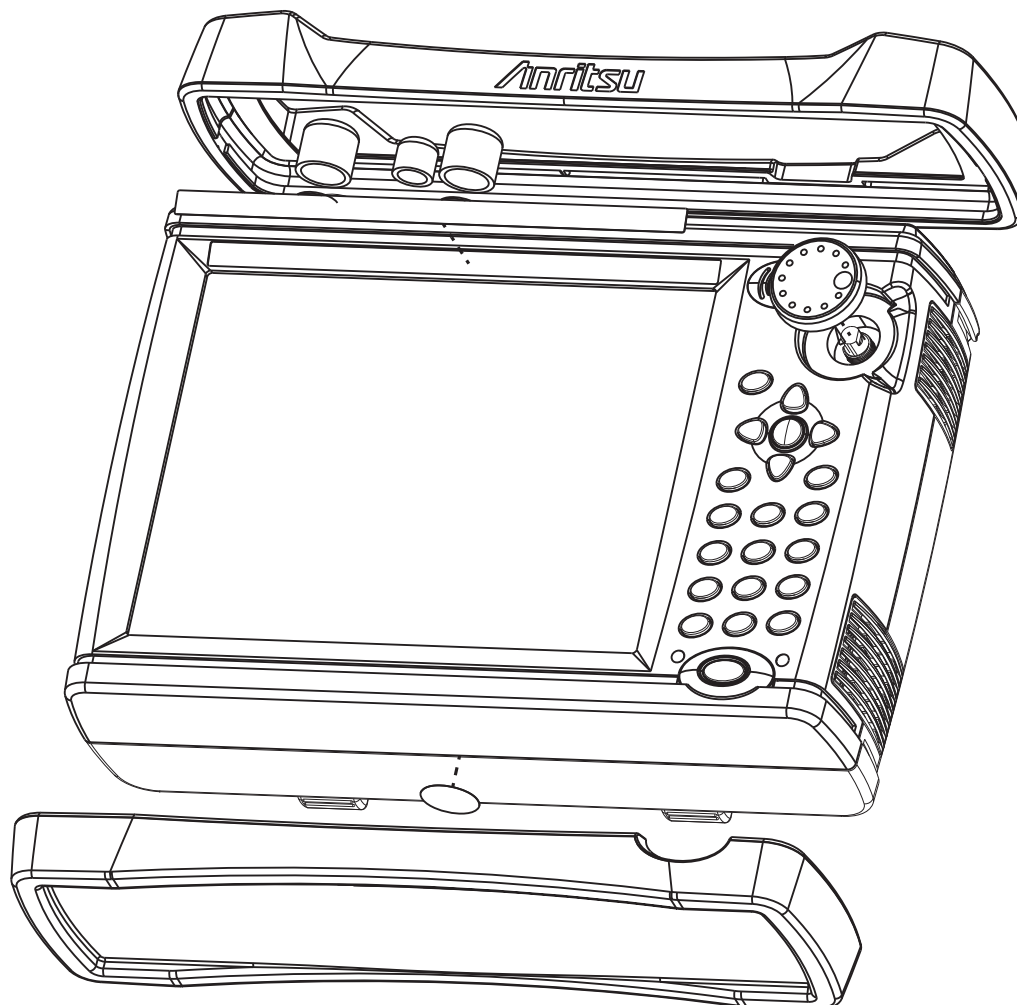

**Figure 6-11.** Removal of Bumpers and Rotary Knob

3. Place the VNA Master face down on a stable work surface that will not scratch the display.
4. Use a Phillips screwdriver to remove the six screws securing the two halves of the case together. The instrument that is shown in [Figure 6-12](#) is not a VNA Master, but the case is the same.



**Figure 6-12.** Remove the Six Screws

5. As you begin to separate the two halves of the case, carefully lift up a small amount first on the right side of the case (as viewed from the back, in other words, the side opposite the keypad when viewed from the front). Then lift the entire case back away from the case front far enough to clear the internal parts and the vent grills. Open the case as if opening a book, laying the back to the left, hinging the two case halves on the one cable (battery power) that links the two case halves together (refer to [Figure 6-13](#)). Take care to avoid damage to the cable or the connector.
6. With the VNA Master back case laying flat beside the front case, remove the battery cable connector from the Mother Board (item 1 in [Figure 6-13](#)). The two halves of the case may then be separated.

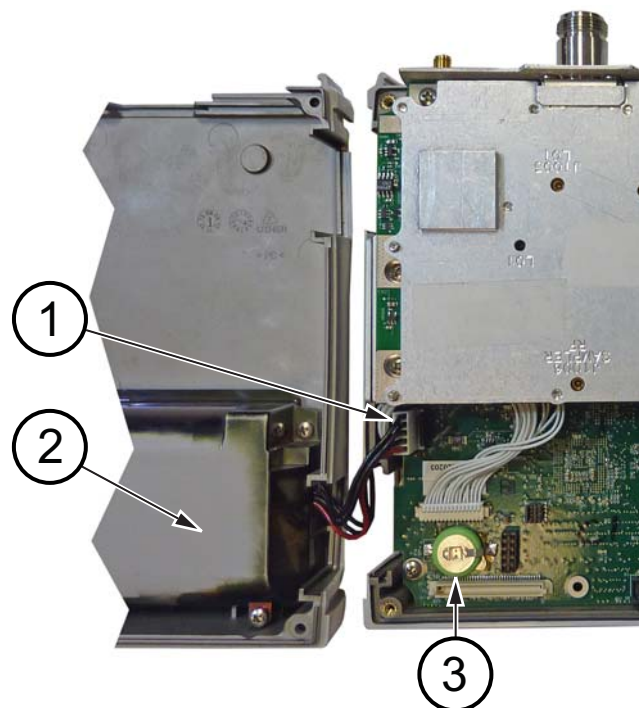

1. Battery Connector
2. Battery Compartment
3. Real Time Clock Battery

**Figure 6-13.** VNA Master Case Opened 180 Degrees

**Case Reassembly:**

7. Closing the case is the reverse of opening.
8. Connect the battery cable to the Mother board and close the case, as described in [“Case Reassembly:” on page 6-16](#). Tuck excess battery cable behind battery connector.
9. When closing the case, take care to align the top connector panel into the case grooves, and to align the 3 vents with grooves in the case halves. Ensure that the battery cable is not pinched by the case.
10. Torque the 6 case screws to 6 lbf · in (0.68 N · m).



## 6-7 PCB Assembly Replacement (MS20xB and MS203xB)

This section describes the removal and replacement of the Main/VNA and Main/VNA/DSP PCB assemblies and the SPA PCB, which are attached to the VNA Master Front Case. This section is preliminary to the removal and replacement of the Main/VNA PCB Assembly (MS20xB Mother Board), the Main/VNA/DSP PCB Assembly (MS203xB Mother Board), or the SPA PCB. The term **Main PCB Assembly** refers to both types (for MS20xB or MS203xB).

This step is also necessary before any of the remaining replacement procedures.

**Note** Procedures in this section are generic, and apply to many similar instruments. Photos and illustrations are representative and may not match your instrument.

1. Open the case as described in [Section 6-6 “Opening the Instrument Case”](#) on page 6-14.

**Note** The PCB Assembly that is shown in [Figure 6-14](#) is not a VNA Master, but the removal steps are appropriate.

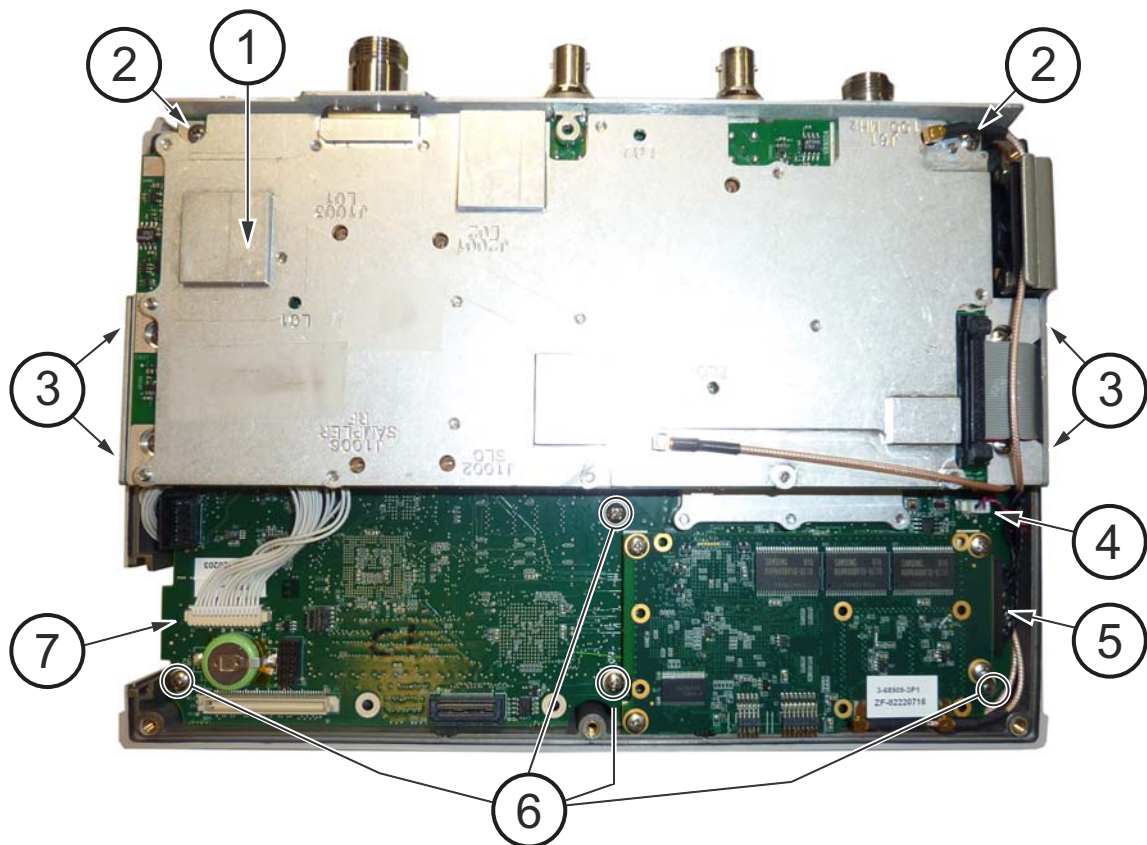

1. SPA PCB
2. 2 screws holding SPA PCB Assembly to Top Connector Panel
3. 4 screws (2 each side) holding SPA PCB Assembly to Main/VNA PCB Bracket
4. Fan Cable Connector to Mother Board
5. LCD Connector to Mother Board
6. 4 screws holding Main/VNA PCB Assembly to Case Front
7. Keypad Connector to Mother Board

**Figure 6-14.** PCB Assembly Removed from the Case (SPA PCB shown)

2. Disconnect the Keypad PCB connector (item 7 in [Figure 6-14](#)), the Fan Assembly cable connector (item 4 in [Figure 6-14](#)), and the LCD connector (item 5 in [Figure 6-14](#)).
3. Use a Phillips screwdriver to remove the 4 screws (item 6 in [Figure 6-14](#)) that secure the entire PCB assembly to the front case.
4. After the screws are removed, the entire PCB Assembly (including the top connector panel) can be removed from the case.

Models MS2024B and MS2025B use the same 4 screws to hold the Mother Board to the case as do models MS2034B and MS2035B.

#### Installation of PCB Assembly:

5. Installation is the reverse of removal.
6. Carefully insert the PCB Assembly and its attached top connector panel into the case. Align the top connector panel and the vent grills with grooves in the case. Confirm that none of the cables will be pinched when the back case is replaced.
7. On VNA Master models MS2024B and MS2025B, replace the 4 screws that hold the Mother Board to the case (item 6 in [Figure 6-14](#)). Torque these screws to 6 lbf ·in (0.68 N ·m).
8. On VNA Master models MS2034B and MS2035B, replace the 4 screws that hold the Mother Board to the case (the same screws as described in [Step 7](#)),
  - a. If the SPA PCB has been separated from the Mother Board PCB assembly, then replace the 4 screws (2 screws on each side, item 3 in [Figure 6-14](#)) that attach the SPA PCB Assembly to the side brackets of the Mother Board. Torque these 4 screws to 7.5 lbf ·in (0.85 N ·m).
  - b. Also replace the 2 screws (item 2 in [Figure 6-14](#)) that hold the SPA PCB to the top connector panel.
  - c. Reattach any cables that may have been removed.
9. Connect the battery cable to the Mother board and close the case, as described in Section “[Case Reassembly:](#)” on page 6-16.
10. Torque the 6 case screws to 6 lbf ·in (0.68 N ·m).



## 6-8 SPA Assembly Replacement

This section describes the removal of the Spectrum Analyzer Assembly board.

**Parts:**

- ND72119 – SPA PCB Assembly for MS2034B and MS2035B instruments

**Procedure:**

1. Open the case as described in [Section 6-6 “Opening the Instrument Case”](#) on page 6-14.

**Note** The PCB Assembly that is shown in [Figure 6-15](#) is not a VNA Master, but the removal steps are appropriate.

2. Remove the PCB Assembly from the front panel as described in [Section 6-7 “PCB Assembly Replacement \(MS202xB and MS203xB\)”](#) on page 6-17.

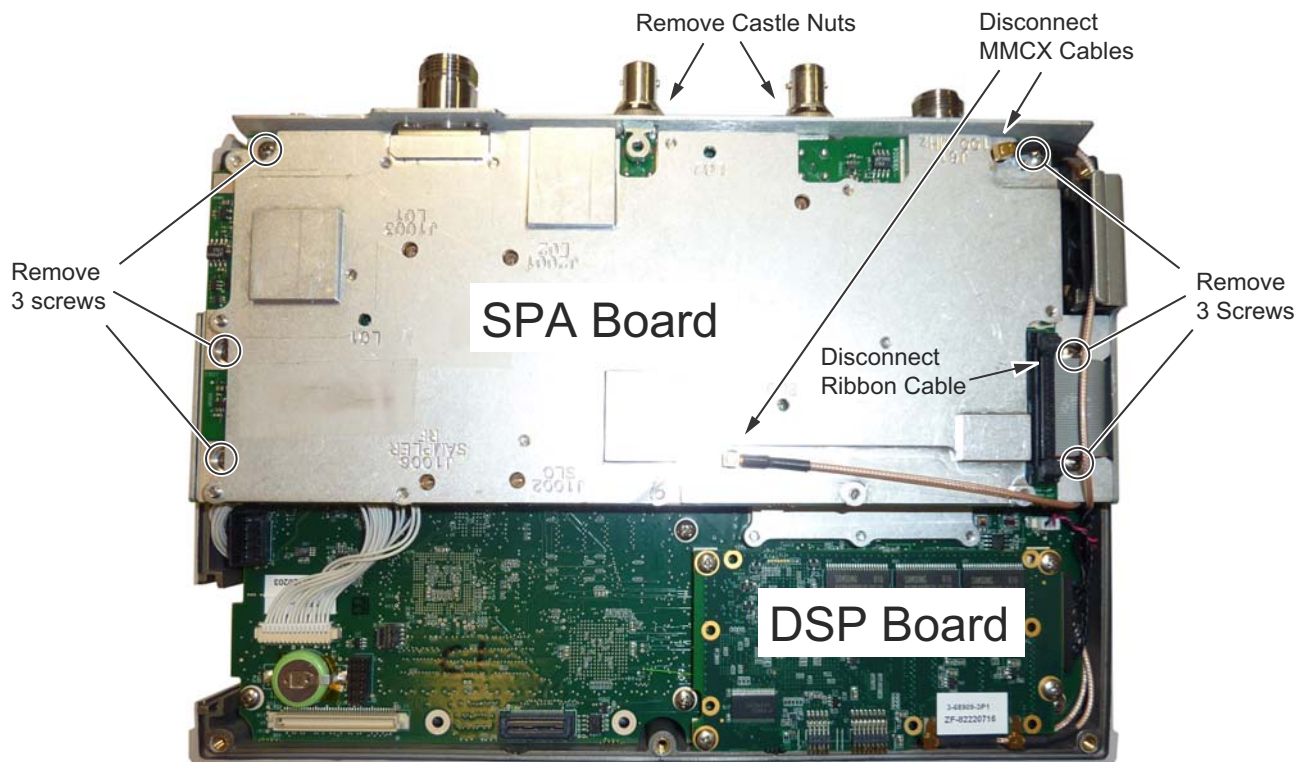

**Figure 6-15.** Removing the SPA PCB Assembly

## PCB Assembly Out Of Case

Figure 6-16 shows the PCB assembly as viewed from the top and from the bottom.

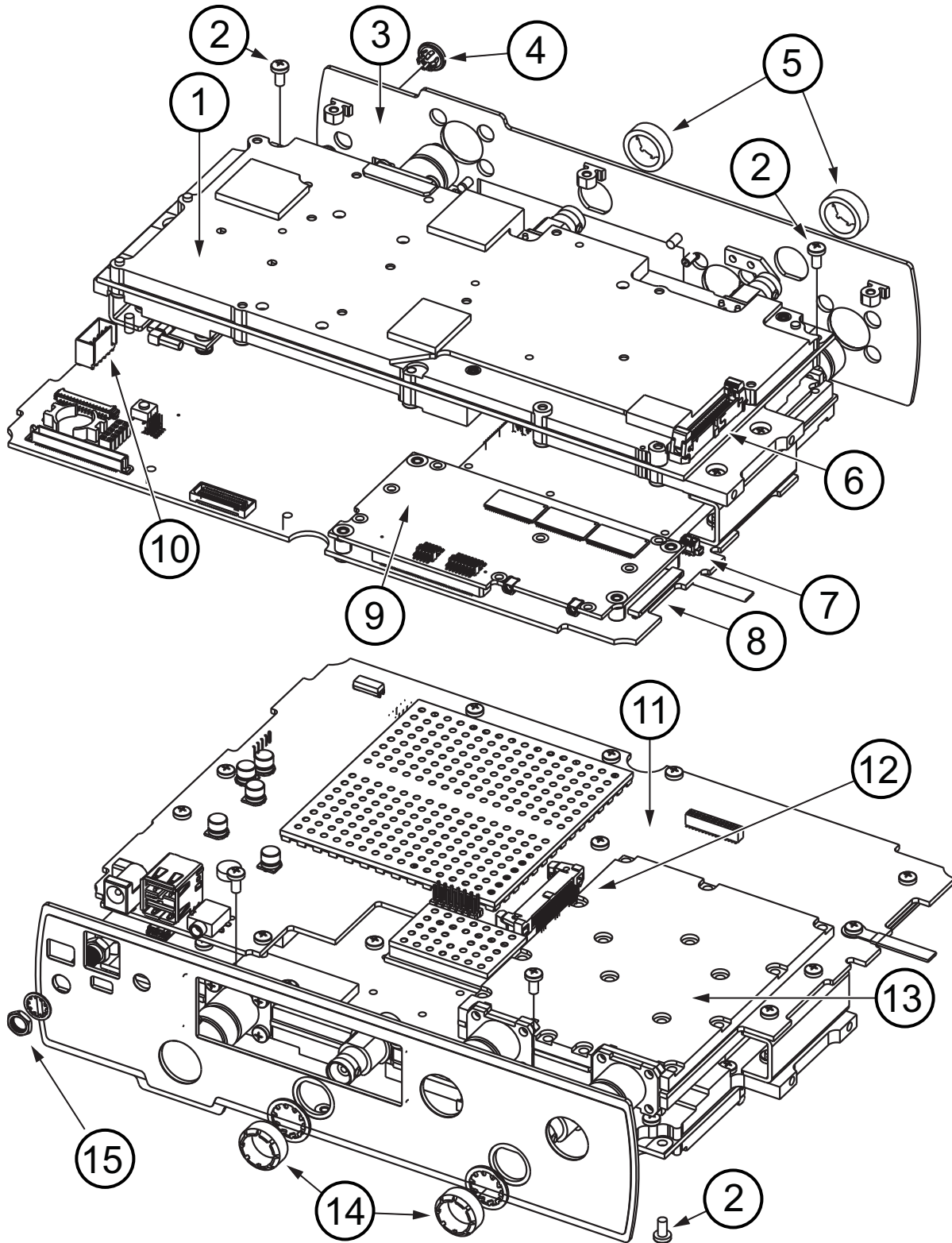

**Figure 6-16.** Main/VNA PCB Assembly (with SPA PCB) Removed from Case

**Table 6-1.** Numbered Items in [Figure 6-16](#)

1	SPA PCB Assembly
2	2 Screws attaching SPA PCB to Top Connector Panel
3	Connector Panel
4	Hole Plug, if Option 31 (GPS) is not installed
5	Castellated BNC dress nuts
6	SPA PCB Connector for ribbon cable to Mother Board
7	Fan connector on Mother Board
8	LCD connector on Mother Board
9	DSP PCB
10	Battery connector on Mother Board
11	Mother Board
12	Mother Board connector J1 for ribbon cable to SPA PCB
13	VNA shield (attached to Mother Board)
14	Castellated BNC dress nuts
15	GPS Antenna SMA connector

3. Use the Anritsu Tool T1451 to remove the castellated BNC dress nuts from the External Reference connector and the External Trigger connector (shown in [Figure 6-15](#) and [Figure 6-16](#)). Save the washers.
4. Remove the Main/VNA board ribbon connector from the SPA PCB.
5. Use needle-nose pliers to remove the RF cables from the 2 MMCX connectors (SPA board to DSP board).
6. Use a Phillips-head screwdriver to remove the 6 screws (refer to [Figure 6-15](#)) retaining the SPA board. Two of these screws secure the SPA PCB to the top connector panel. The other four screws connect the SPA PCB to the brackets at the sides of the Mother Board. (Refer also to [Figure 6-14](#).)
7. Slide the SPA board out of the top connector panel.

#### Installing the SPA PCB Assembly:

8. Installation is the reverse of removal. Follow replacement instructions for each of the parts and assemblies that were removed, as appropriate.
9. Slide the replacement SPA board into the top connector panel and onto the brackets at the sides of the Mother Board.
10. Use a Phillips-head screwdriver to secure the 6 screws (refer to [Figure 6-15](#)) retaining the SPA board to the top connector panel and to the Mother Board. Torque these six screws to 7.5 lbf · in (0.85 N · m).
11. Use the Anritsu Tool T1451 to attach the castellated BNC dress nuts to the External Reference connector and the External Trigger connector (shown in [Figure 6-15](#) and [Figure 6-16](#)). Use the washers that were saved in [Step 3](#), and torque the nuts to 7.5 lbf · in (0.85 N · m).
12. Connect the ribbon cable (Item 5 in [Figure 6-17](#)) from the Mother Board to the SPA PCB.
13. Connect the RF cables from the DSP board to the SPA board. Refer to [Figure 6-17](#) for the locations of the MMCX connectors.
 

The RF cable from MMCX connector DSP J1 (100 MHz, Item 4 in [Figure 6-17](#)) connects to SPA PCB J61 (Item 9 in [Figure 6-17](#)).

The RF cable from MMCX connector DSP J2 (140 MHz SPA IF, Item 3 in [Figure 6-17](#)) connects to SPA PCB J4 (Item 6 in [Figure 6-17](#)).
14. Connect the battery cable to the Mother board and close the case, as described in Section “[Case Reassembly:](#)” on [page 6-16](#).

PCB Cable connections

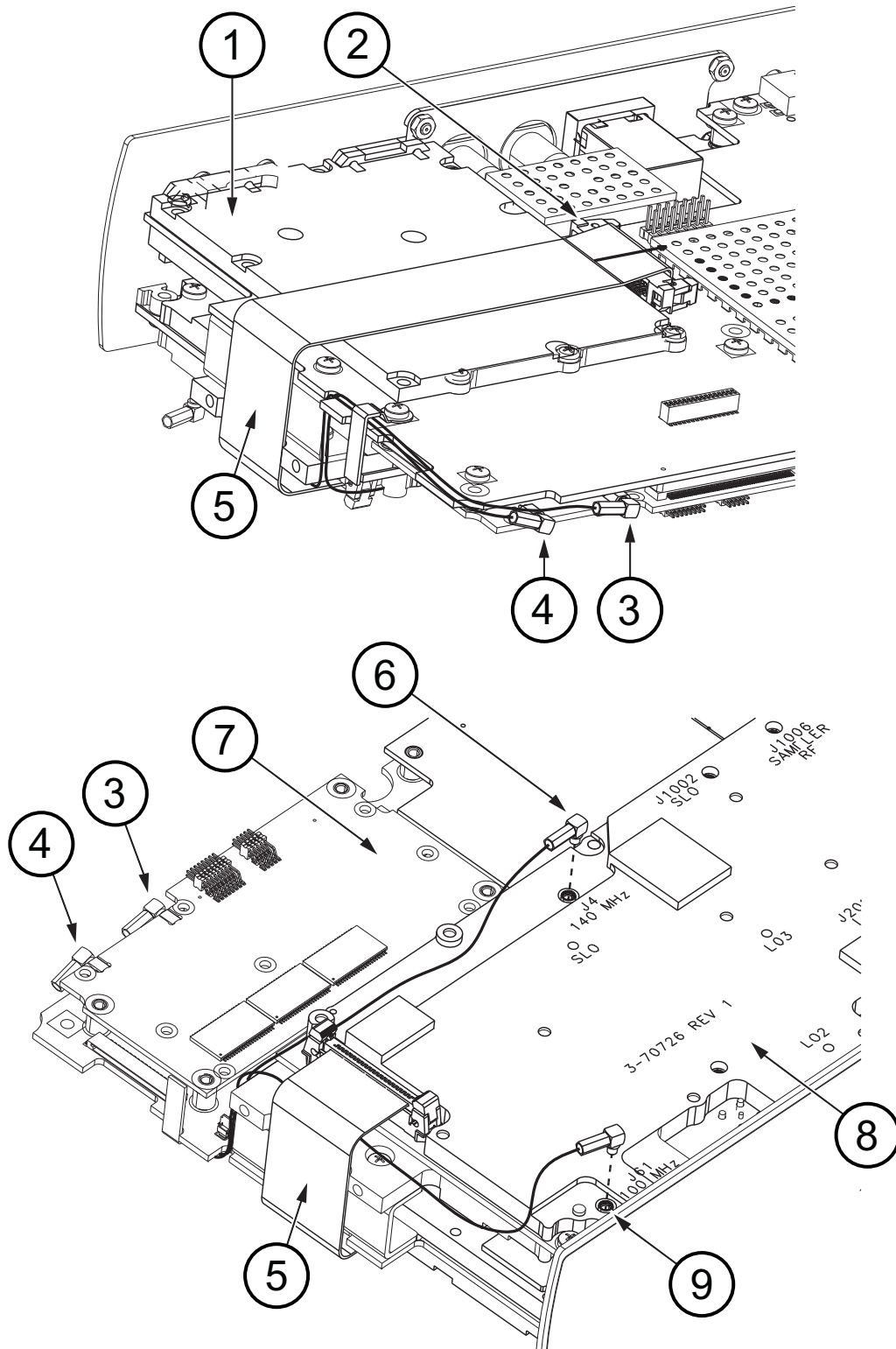

Figure 6-17. Connections Between PCB Assemblies

**Table 6-2.** Numbered Items in [Figure 6-17](#)

1	VNA shield attached to Mother Board (DO NOT remove shields)
2	MB to SPA PCB Ribbon cable at Mother Board connector J1
3	DSP PCB connector J2 (140 MHZ SPA IF) – RF cable attaches to SPA PCB connector J4 (item 6)
4	DSP PCB connector J1 (100 MHZ) – RF cable attaches to SPA PCB connector J61 (item 9)
5	Ribbon cable from MB to SPA PCB
6	MMCX connector J4 on SPA PCB (140 MHz IF)
7	DSP PCB
8	SPA PCB
9	MMCX connector J61 on SPA PCB (100 MHz)

## 6-9 GPS (Option 31) Replacement

This procedure provides instructions for removing and replacing the GPS Module.

### Parts:

- ND70320 – GPS Receiver Module (Option 31) for all VNA Master Instruments

### Procedure:

1. Open the case as described in [Section 6-6 “Opening the Instrument Case” on page 6-14](#).
2. Remove the PCB Assembly from the front panel as described in [Section 6-7 “PCB Assembly Replacement \(MS202xB and MS203xB\)” on page 6-17](#).
3. Partially remove the SPA board (if this replacement is for an MS2034B or MS2035B VNA Master) as described in [Section 6-8 “SPA Assembly Replacement” on page 6-19](#).

In the MS2024B or MS2025B, no SPA PCB blocks access to the GPS Module.

**Note** In the MS2034B or MS2035B, the SPA board RF cables that connect to the DSP board do not need to be removed when replacing the GPS Module.

- a. Use the Anritsu Tool T1451 to remove the castellated BNC dress nuts from the External Reference connector and the External Trigger connector (shown in [Figure 6-15 on page 6-19](#) and [Figure 6-16 on page 6-20](#)). Save the washers.
  - b. Use a Phillips-head screwdriver to remove the 6 screws (refer to [Figure 6-15](#)) retaining the SPA board. Two of these screws secure the SPA PCB to the top connector panel. The other four screws connect the SPA PCB to the brackets at the sides of the Mother Board. (Refer also to [Figure 6-14 on page 6-17](#).)
  - c. Slide the SPA board out of the top connector panel, and carefully lay it to the side without applying stress to the cables.
4. Use a 5/16 inch wrench to remove the nut and washer from the GPS SMA connector. Push the connector through the top panel. Refer to [Figure 6-18](#).
  5. Referring to [Figure 6-18](#), use a Phillips screwdriver to remove the 2 screws retaining the GPS module to the Main/VNA board.
  6. Carefully lift straight up on the GPS module to remove. The back of the GPS module board is directly connected to the Main/VNA board.

### Installing the GPS module:

7. Installation is the reverse of removal. Follow replacement instructions for each of the parts and assemblies that were removed, as appropriate.
8. Use a Phillips screwdriver to install the 2 screws retaining the GPS module to the Main/VNA board. Torque these screws to 7.5 lbf · in (0.85 N · m).
9. If necessary, snap the GPS Antenna Cable MCX connector into place on the GPS Receiver Module.
10. Install the SMA connector into the top connector panel, add the lock washer and the nut.
11. Use two 5/16 inch ( $\cong$  8 mm) wrenches to tighten the GPS Antenna SMA connector to the top connector panel. Torque the nut to 7.5 lbf · in (0.85 N · m).
12. Replace the SPA board as described in [Section “Installing the SPA PCB Assembly:” on page 6-21](#).
13. Connect the battery cable to the Mother board and close the case, as described in [Section “Case Reassembly:” on page 6-16](#).



**Note** The PCB Assembly that is shown in [Figure 6-18](#) is not a VNA Master, but the removal steps are appropriate.

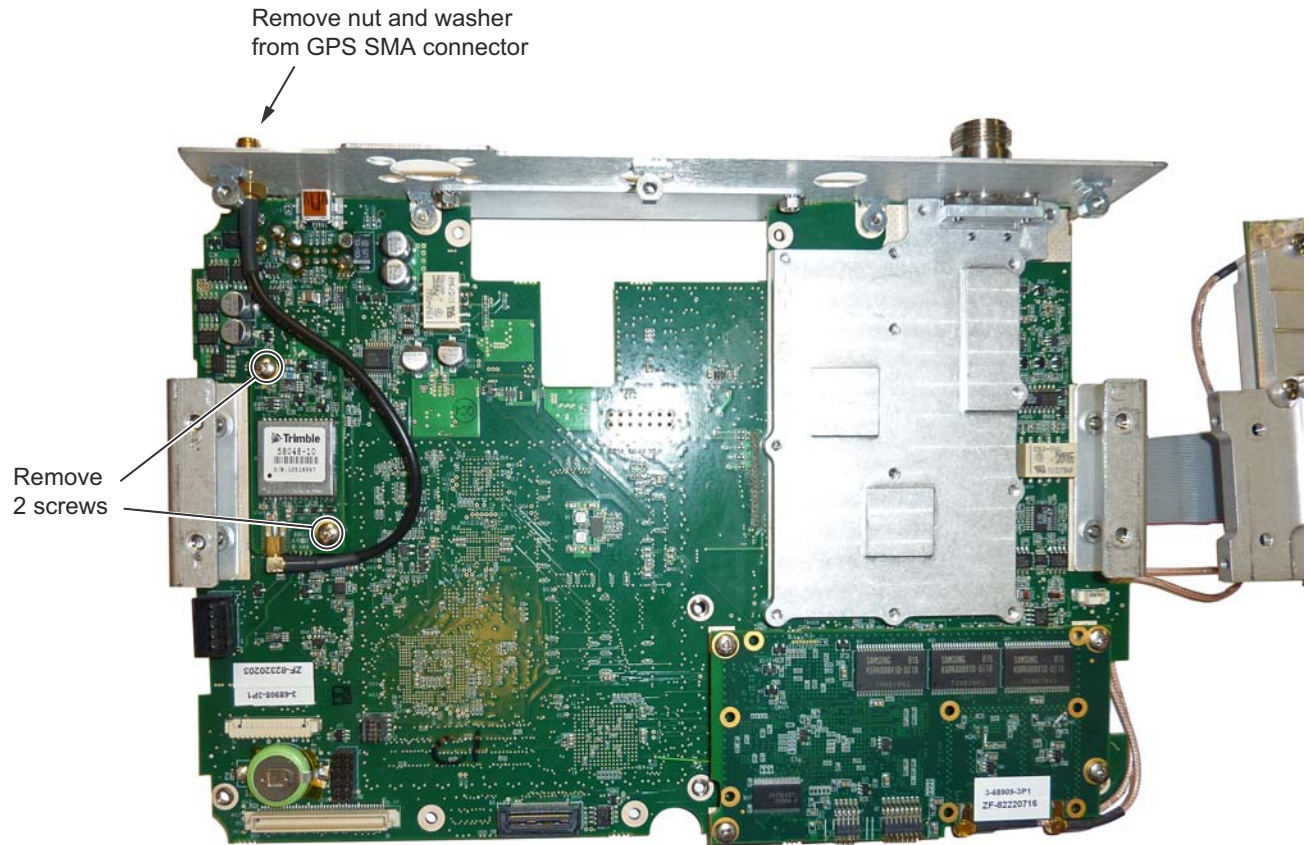

**Figure 6-18.** Removing the GPS Module from the Main/VNA board (SPA board set to the side)

## 6-10 Ethernet PCB Assembly (Option 411) Replacement

This procedure provides instructions for removing and replacing the Ethernet PCB Assembly. This option includes an option plate (with an opening for the Ethernet connector) that is attached to the top connector panel with 4 nuts.

### Parts:

- ND72101 – Ethernet Option PCB Assembly, Option 411

### Procedure:

1. Open the case as described in [Section 6-6 “Opening the Instrument Case” on page 6-14](#).
2. Remove the PCB Assembly from the front case as described in [Section 6-7 “PCB Assembly Replacement \(MS202xB and MS203xB\)” on page 6-17](#).
3. If the instrument is an MS2034B or MS2035B, then partially remove the SPA board as described in [Table 6-8, “SPA Assembly Replacement” on page 6-19](#).

<b>Note</b>	In the MS2024B or MS2025B, no SPA PCB blocks access to the GPS Module. In the MS2034B or MS2035B, the SPA board RF cables that connect to the DSP board do not need to be removed when replacing the Ethernet PCB Assembly.
-------------	--

- a. Use the Anritsu Tool T1451 to remove the castellated BNC dress nuts from the External Reference connector and the External Trigger connector (shown in [Figure 6-15 on page 6-19](#) and [Figure 6-16 on page 6-20](#)). Save the washers.
  - b. Use a Phillips-head screwdriver to remove the 6 screws (refer to [Figure 6-15](#)) retaining the SPA board. Two of these screws secure the SPA PCB to the top connector panel. The other four screws connect the SPA PCB to the brackets at the sides of the Mother Board. (Refer also to [Figure 6-14 on page 6-17](#).)
  - c. Slide the SPA board out of the top connector panel, and carefully lay it to the side without applying stress to the cables.
4. Refer to [Figure 6-19](#) for removing the 4 screws retaining the Ethernet PCB Assembly to the Main/VNA board. The Ethernet PCB Assembly has 3 screws on one side (attaching directly to the Mother Board) and 1 screw on the opposite side (item 1 in [Figure 6-19](#), which attaches to the VNA shield).
  5. Use a Phillips screwdriver to remove the 2 screws that hold the top connector panel to the main PCB Assembly.

<b>Caution</b>	Before attempting to remove the Ethernet PCB Assembly, you must remove the top connector panel. The Ethernet PCB Assembly must be removed carefully in order to protect vulnerable parts that can be easily damaged.
----------------	--

- a. One screw is adjacent to the single screw for the Ethernet PCB (item 1 in [Figure 6-19](#)) and holds a bracket of the top connector panel to the shield on the VNA PCB.
  - b. The other screw attaches the Mother Board to the top connector panel and is adjacent to the top Ethernet PCB screw into the Mother Board, near the Ethernet connector.
  - c. Slide the top connector panel free of the PCB assembly and free of the connectors.
6. Carefully remove the Ethernet PCB Assembly.

### Installing the Ethernet PCB Assembly:

7. Installation is the reverse of removal. Follow replacement instructions for each of the parts and assemblies that were removed, as appropriate.
8. Close the case as described in [Section “Case Reassembly:” on page 6-16](#).



## Ethernet PCB Assembly

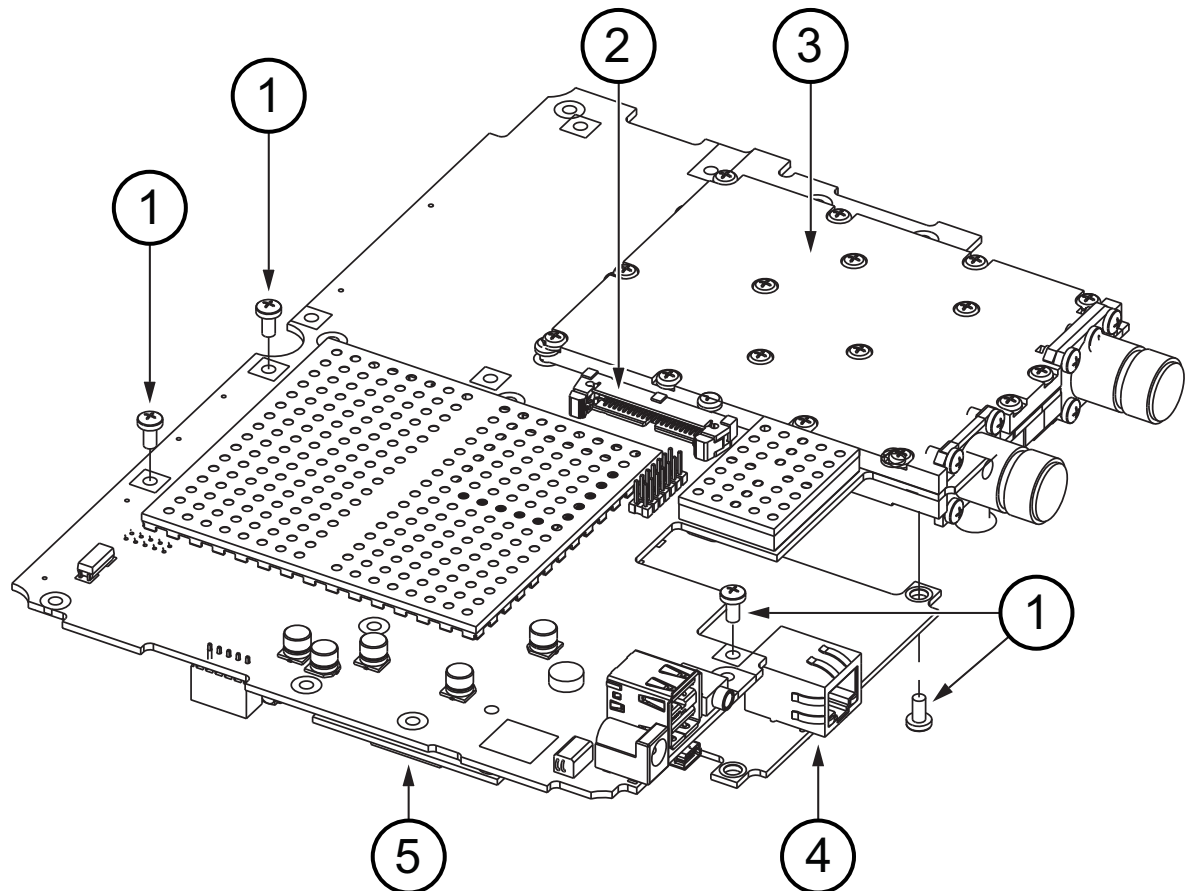

1. Screw (4 total) to attach Option 411 PCB to Main/VNA PCB Assembly
2. Connector J1 (Mother Board to SPA PCB ribbon cable connector)
3. VNA shield
4. Ethernet LAN Connector
5. GPS PCB on Mother Board

**Figure 6-19.** Option 411 (Ethernet LAN) PCB Attached to Mother Board

## 6-11 Main/VNA PCB Assembly Replacement

This procedure provides instructions for removing and replacing the Main/VNA PCB Assembly for MS2024B and MS2025B instruments.

<b>Note</b>	When ordering the Main/VNA PCB Assembly, all options that are installed on the instrument must be stated on the order.
-------------	--

### Parts:

- ND72051 – Main/VNA PCB Assembly for MS2024B instruments
  - Does not include GPS Receiver Module
  - Does not include Ethernet Option PCB Assembly
- ND72052 – Main/VNA PCB Assembly for MS2025B instruments
  - Does not include GPS Receiver Module
  - Does not include Ethernet Option PCB Assembly

### Procedure:

1. Open the case as described in [Section 6-6 “Opening the Instrument Case” on page 6-14](#).
2. Remove the PCB Assembly from the front panel as described in [Section 6-7 “PCB Assembly Replacement \(MS202xB and MS203xB\)” on page 6-17](#).
3. Remove the GPS board (if option 31 is installed) from the Main/VNA PCB Assembly as described in [Section 6-9 “GPS \(Option 31\) Replacement” on page 6-24](#).
4. Remove the Ethernet PCB Assembly (if option 411 is installed) from the Main/VNA PCB Assembly as described in [Section 6-10 “Ethernet PCB Assembly \(Option 411\) Replacement” on page 6-26](#).

### Installing the Main/VNA PCB Assembly:

5. Installation is the reverse of removal. Follow replacement instructions for each of the parts and assemblies that were removed, as appropriate.
6. Close the case as described in [Section “Case Reassembly:” on page 6-16](#).

## 6-12 Main/VNA/DSP PCB Assembly Replacement

This procedure provides instructions for removing and replacing the Main/VNA/DSP PCB Assembly for MS2034B and MS2035B instruments.

<b>Note</b>	When ordering the Main/VNA/DSP PCB Assembly, all options that are installed on the instrument must be stated on the order.
-------------	--

### Parts:

- ND72117 – Main/VNA/DSP PCB Assembly for MS2034B instruments
  - Does not include SPA PCB Assembly
  - Does not include GPS Receiver Module
  - Does not include Ethernet Option PCB Assembly
- ND72118 – Main/VNA/DSP PCB Assembly for MS2035B instruments
  - Does not include SPA PCB Assembly
  - Does not include GPS Receiver Module
  - Does not include Ethernet Option PCB Assembly

### Procedure:

1. Open the case as described in [Section 6-6 “Opening the Instrument Case”](#) on page 6-14.
2. Remove the PCB Assembly from the front panel as described in [Section 6-7 “PCB Assembly Replacement \(MS202xB and MS203xB\)”](#) on page 6-17.
3. Remove the SPA board (if the instrument is an MS2034B or MS2035B) as described in [Section 6-8 “SPA Assembly Replacement”](#) on page 6-19.
4. Remove the GPS board (if option 31 is installed) from the Main/VNA PCB Assembly as described in [Section 6-9 “GPS \(Option 31\) Replacement”](#) on page 6-24.
5. Remove the Ethernet PCB Assembly (if option 411 is installed) from the Main/VNA PCB Assembly as described in [Section 6-10 “Ethernet PCB Assembly \(Option 411\) Replacement”](#) on page 6-26.

### Installing the Main/VNA/DSP PCB Assembly:

6. Installation is the reverse of removal. Follow replacement instructions for each of the parts and assemblies that were removed, as appropriate.
7. Close the case as described in [Section “Case Reassembly:”](#) on page 6-16.

## 6-13 Fan Assembly Replacement

This procedure provides instructions for removing and replacing the Fan Assembly.

### Parts:

- 3-72779 – Fan Assembly

### Procedure:

1. Open the case as described in [Section 6-6 “Opening the Instrument Case”](#) on page 6-14.
2. Remove the PCB assembly from the case front as described in [Section 6-7 “PCB Assembly Replacement \(MS202xB and MS203xB\)”](#) on page 6-17.

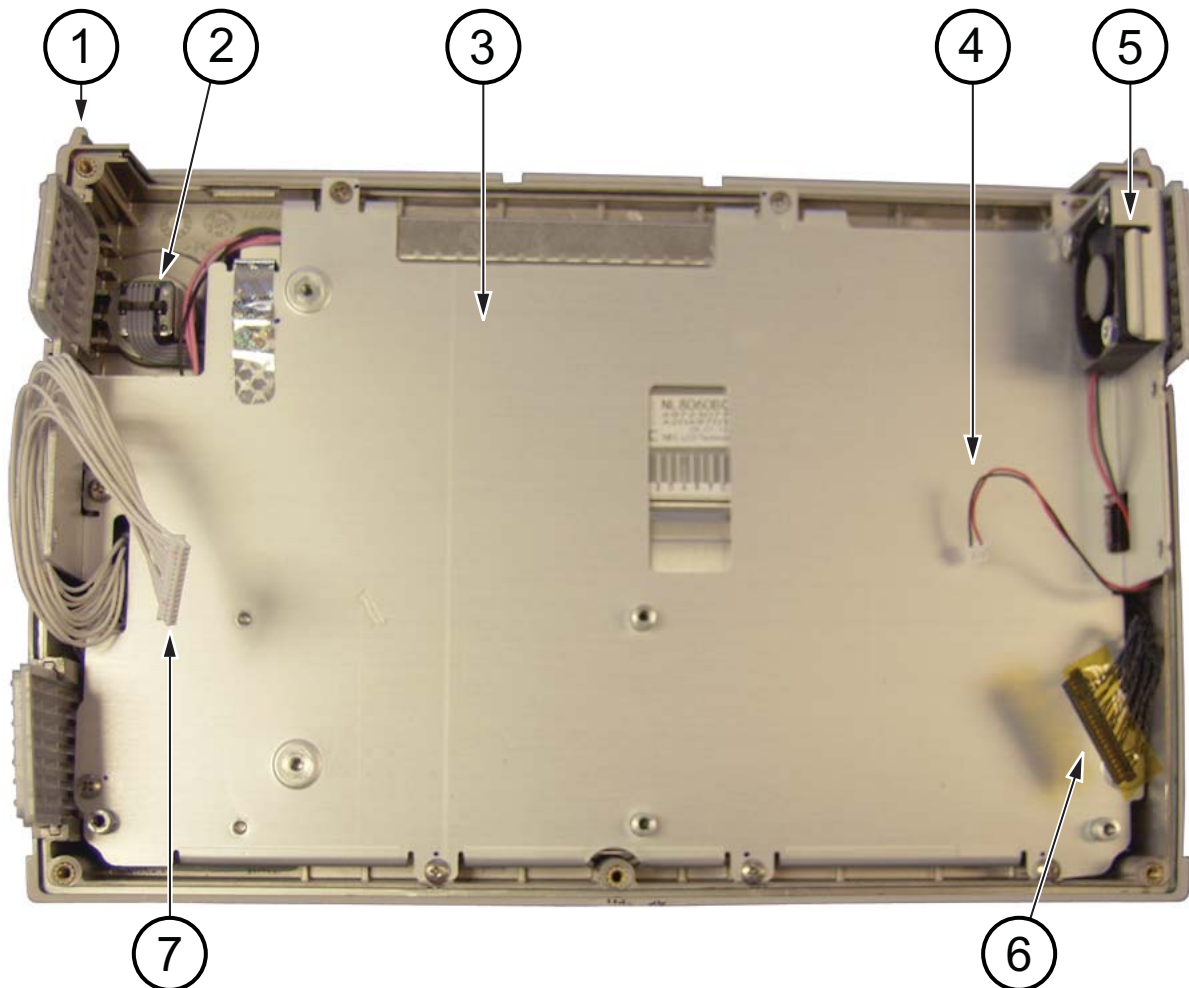

1. Front case assembly
2. Rotary encoder
3. Metal pan securing the LCD assembly
4. Cable connection for fan (cable passes through LCD assembly)
5. Fan assembly
6. Cable connection from LCD to Mother Board
7. Cable connection from keypad to Mother Board

**Figure 6-20.** Case Front with LCD and Fan

3. Cut and remove the silicone rubber fasteners holding the Fan Assembly to the metal pan. Refer to [Figure 6-20](#) and [Figure 6-21](#).

4. Extract the fan cable from the metal pan and remove the fan assembly.

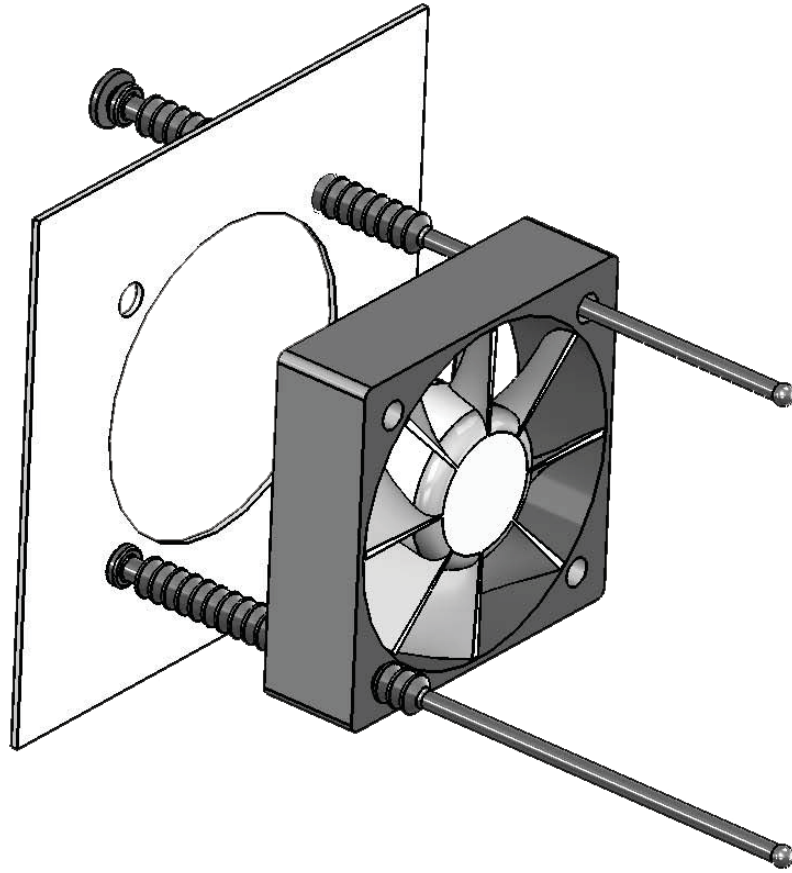

**Figure 6-21.** Fan Assembly Replacement

**Installing the Fan Assembly:**

5. Installation is the reverse of removal. Follow replacement instructions for each of the parts and assemblies that were removed, as appropriate.
6. Use new silicone rubber fasteners (supplied with the replacement fan assembly). Pull the fasteners through the metal pan and the fan as shown in [Figure 6-21](#). Trim the fasteners after ensuring that the fan is firmly attached to the bracket.

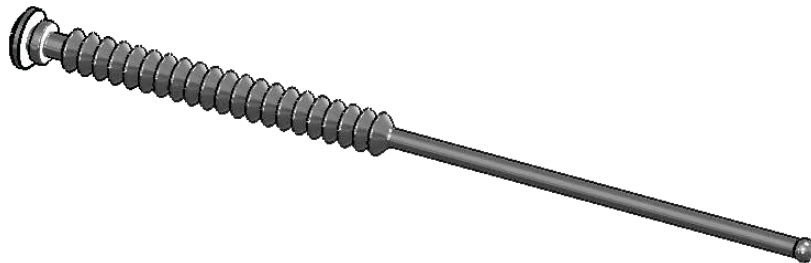

**Figure 6-22.** Fan Fastener, Silicone Rubber

7. Route the fan cable through the opening in the metal pan.
8. Replace the PCB assembly in the case front as described in [Section 6-7 “PCB Assembly Replacement \(MS202xB and MS203xB\)”](#) on page 6-17.
9. Close the case as described in [Section “Case Reassembly:”](#) on page 6-16.

## 6-14 LCD Assembly Replacement

This procedure provides instructions for removing and replacing the Liquid Crystal Display (LCD) after the Main/VNA PCB or Main/VNA PCB/DSP assembly has been separated from the instrument.

### Parts:

- 3-15-147 – LCD Display

### Procedure:

1. Open the case as described in [Section 6-6 “Opening the Instrument Case”](#) on page 6-14.
2. Remove the Main PCB assembly as described in [Section 6-7 “PCB Assembly Replacement \(MS202xB and MS203xB\)”](#) on page 6-17.
3. Remove the 9 screws securing the metal pan (part of LCD Assembly) to the front half of the case. The 5 screws noted by number 1 in [Figure 6-23](#) are flathead screws. The 4 screws noted by number 2 in [Figure 6-23](#) are pan head screws.

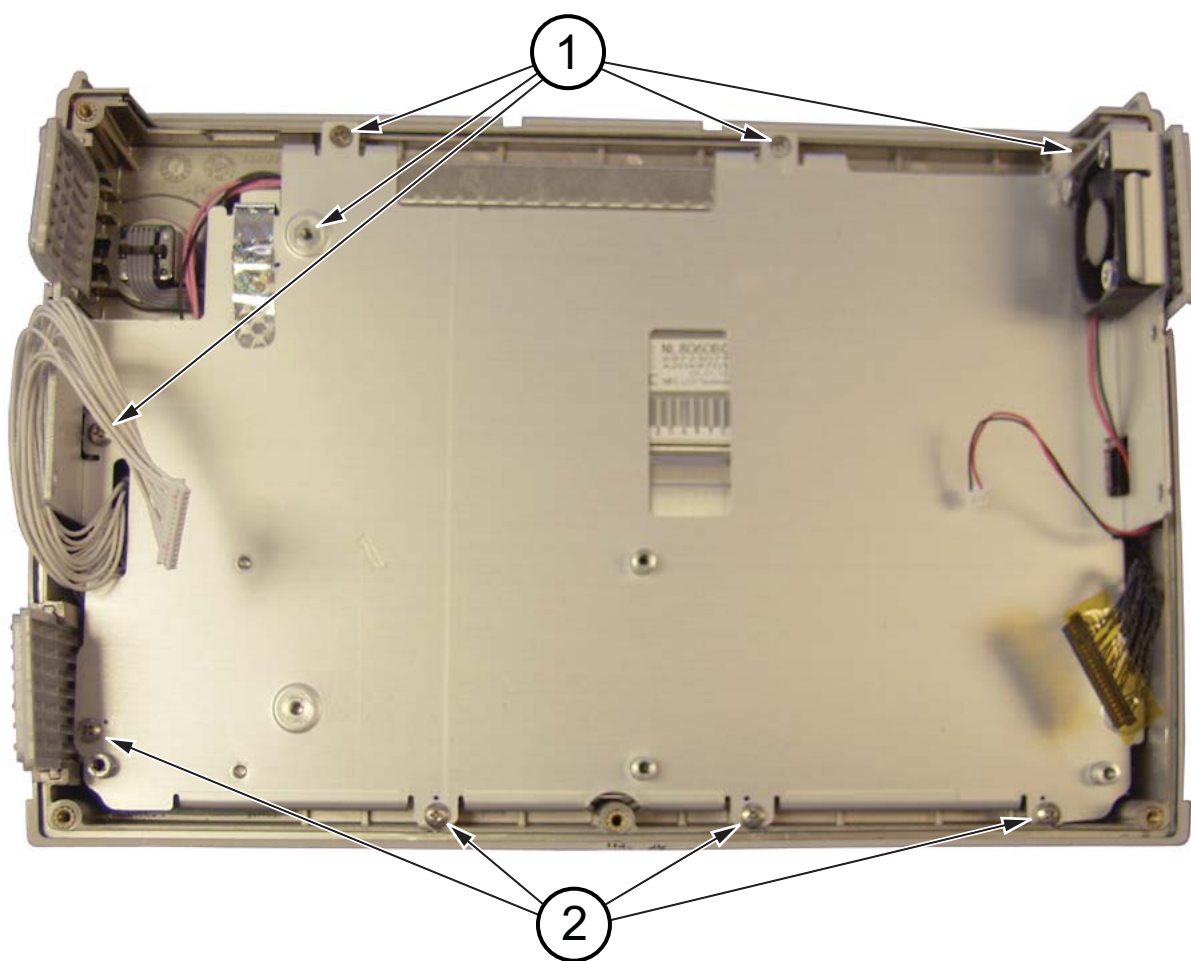

**Figure 6-23.** Nine Screws Secure Metal Pan Over LCD Display

4. Turn over the LCD assembly and disconnect the front half of the case from the LCD Assembly ([Figure 6-24](#)) by disconnecting the cable.



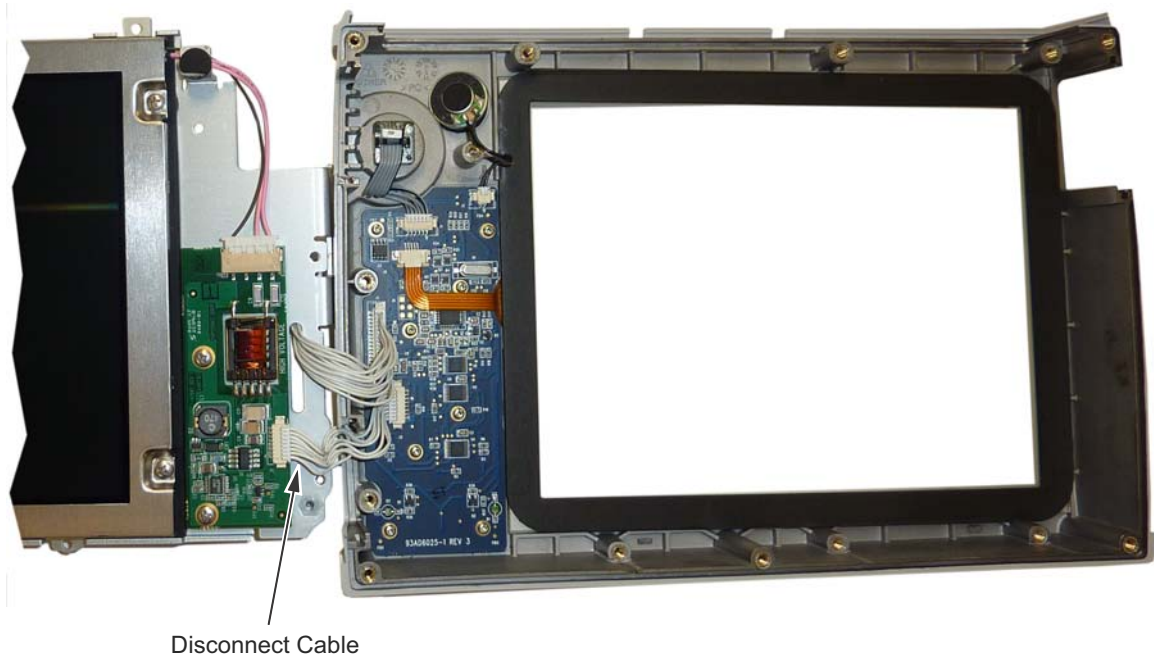

**Figure 6-24.** Replacing the LCD Assembly

5. Use a Phillips screw driver to remove the four screws securing the LCD to the housing ([Figure 6-25](#)).

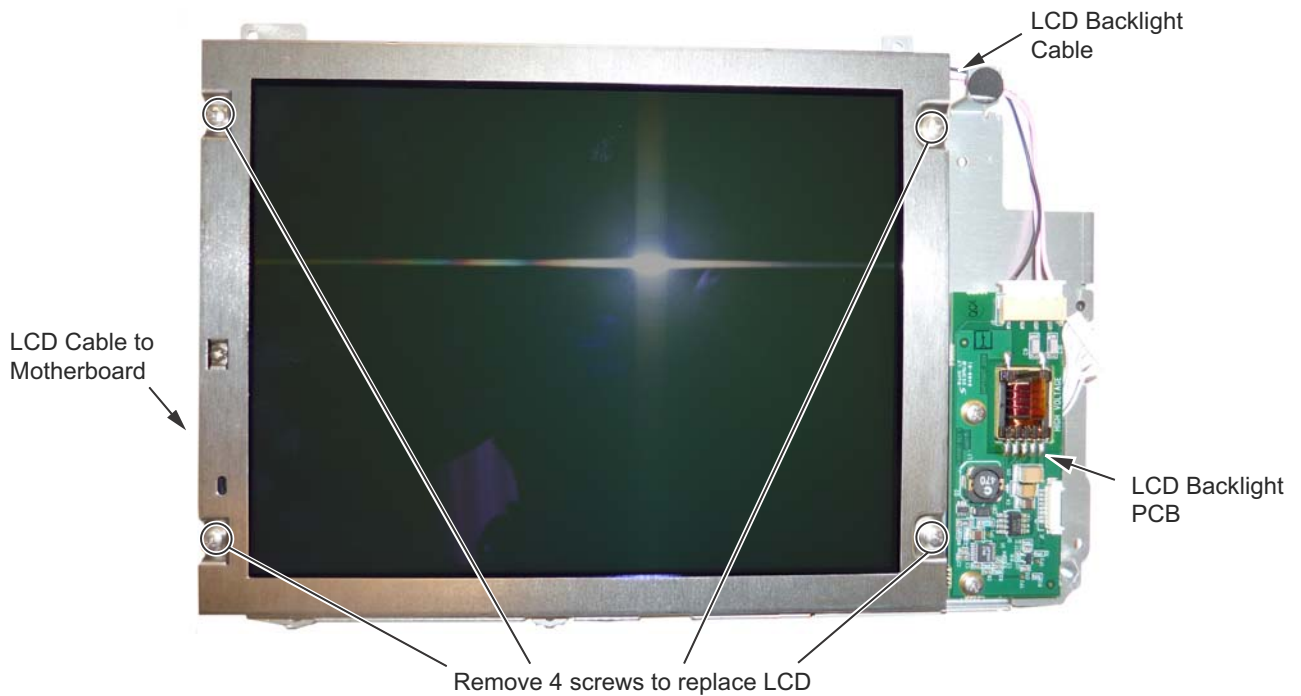

**Figure 6-25.** Replacing the LCD

6. Disconnect the LCD backlight cable from the LCD backlight PCB.
7. Disconnect the LCD cable from the side of the LCD.
8. Carefully remove the LCD.

**Installing the LCD:**

9. Installation is the reverse of removal. Follow replacement instructions for each of the parts and assemblies that were removed, as appropriate.

<b>Note</b>	Pay attention to the routing of the LCD Backlight Cable. The cable must be positioned so that it is not pinched when the unit is reassembled.
-------------	---

10. Close the case as described in Section [“Case Reassembly:”](#) on page 6-16.



## 6-15 LCD Backlight PCB Removal and Replacement

This procedure provides instructions for removing and replacing the VNA Master LCD backlight PCB.

### Parts:

- 3-68567-3 – LCD Backlight Inverter PCB Assembly

### Procedure:

1. Open the case as described in [Section 6-6 “Opening the Instrument Case”](#) on page 6-14.
2. Remove the Main PCB assembly from the front panel as described in [Section 6-7 “PCB Assembly Replacement \(MS202xB and MS203xB\)”](#).
3. Perform [Step 1](#) through [Step 4](#) of [Section 6-14 “LCD Assembly Replacement”](#).
4. Disconnect the LCD backlight cable from the LCD backlight PCB.
5. Use a Phillips screw driver to remove the two screws securing the LCD backlight PCB to the Main PCB assembly ([Figure 6-26](#)).

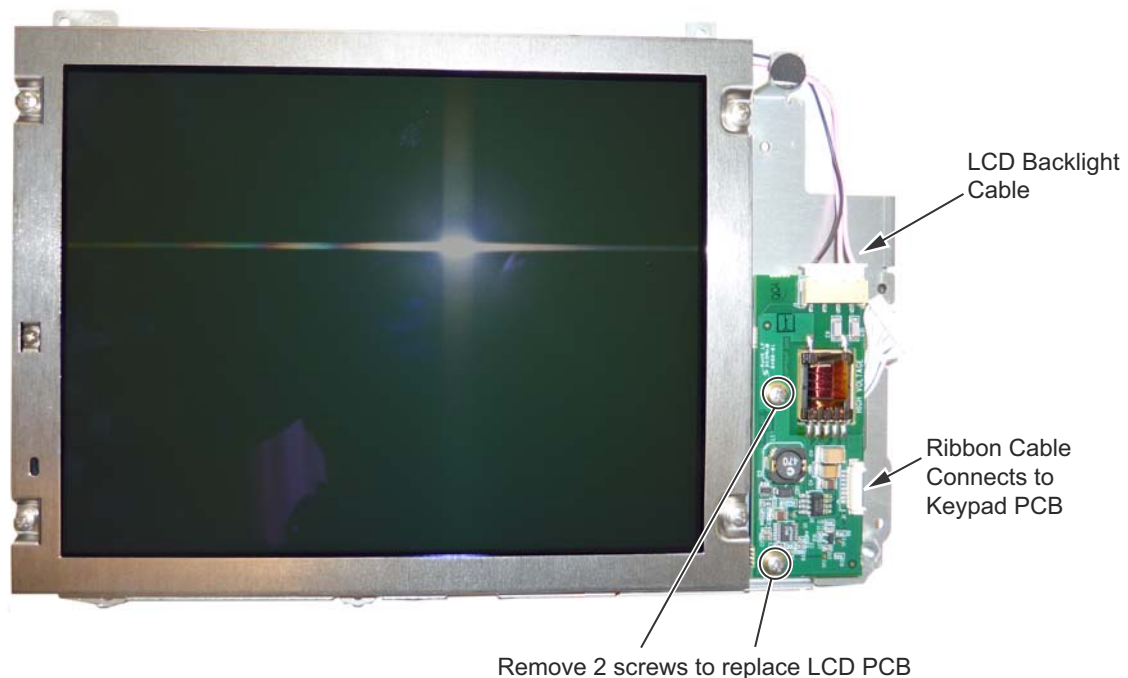

**Figure 6-26.** Replacing the LCD PCB

6. Carefully remove the LCD Backlight PCB.

### Installing the LCD Backlight PCB:

7. Installation is the reverse of removal. Follow replacement instructions for each of the parts and assemblies that were removed, as appropriate.

<b>Note</b>	Pay attention to the routing of the LCD Backlight Cable. The cable must be positioned so that it is not pinched when the unit is reassembled.
-------------	---

8. Close the case as described in [Section “Case Reassembly:”](#) on page 6-16.

## 6-16 Keypad and Keypad PCB Replacement

This procedure provides instructions for removing and replacing the keypad and the keypad PCB.

### Parts:

- 3-72773 – Rubber Keypad
- 3-72811-3 – Main Numeric Keypad PCB Assembly

### Procedure:

1. Open the case as described in [Section 6-6 “Opening the Instrument Case”](#) on page 6-14.
2. Remove the Main PCB assembly from the front panel as described in [Section 6-7 “PCB Assembly Replacement \(MS202xB and MS203xB\)”](#) on page 6-17.
3. Perform [Step 1](#) through [Step 4](#) of [Section 6-14 “LCD Assembly Replacement”](#) on page 6-32.
4. Remove the 8 screws and the cable connectors to remove the Keypad PCB ([Figure 6-27](#)). The Rubber Keypad is located under the Keypad PCB.

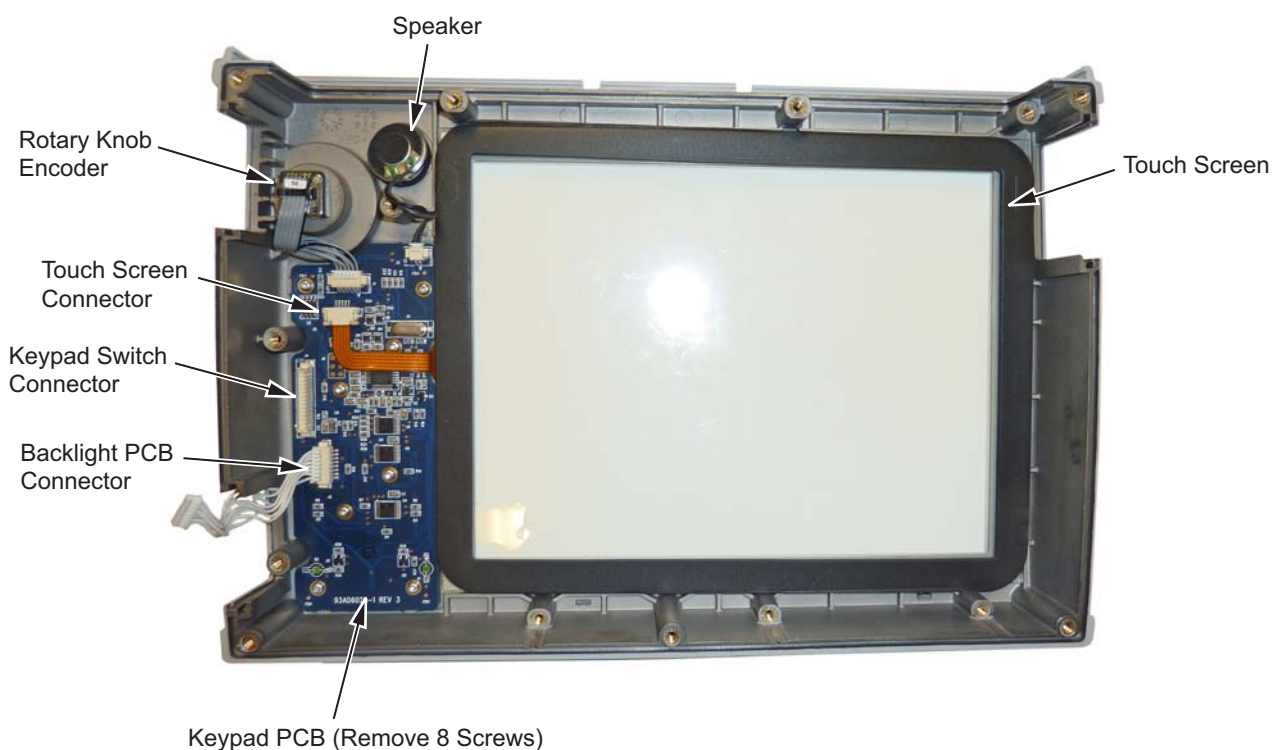

**Figure 6-27.** Front Panel Keypad Replacement

### Installing the Keypad and Keypad PCB:

5. Installation is the reverse of removal. Follow replacement instructions for each of the parts and assemblies that were removed, as appropriate.
6. Close the case as described in [Section “Case Reassembly:”](#) on page 6-16.

## 6-17 Touch Screen Replacement

This procedure provides instructions for removing and replacing the touch screen.

### Parts:

- ND73867 – Touch Screen with Gasket

### Procedure:

1. Open the case as described in [Section 6-6 “Opening the Instrument Case”](#) on page 6-14.
2. Remove the Main PCB assembly from the front panel as described in [Section 6-7 “PCB Assembly Replacement \(MS202xB and MS203xB\)”](#) on page 6-17.
3. Perform [Step 1](#) through [Step 4](#) of [Section 6-14 “LCD Assembly Replacement”](#) on page 6-32.
4. Remove the touch screen flex circuit connector from the Keypad PCB by pulling the tabs on each side of the connector away from the connector and in the direction of the flex circuit. Refer to [Figure 6-28](#).
5. Pull the Touch Screen cable out of the connector housing.
6. Remove the Touch Screen from the Bezel by pulling it straight up.

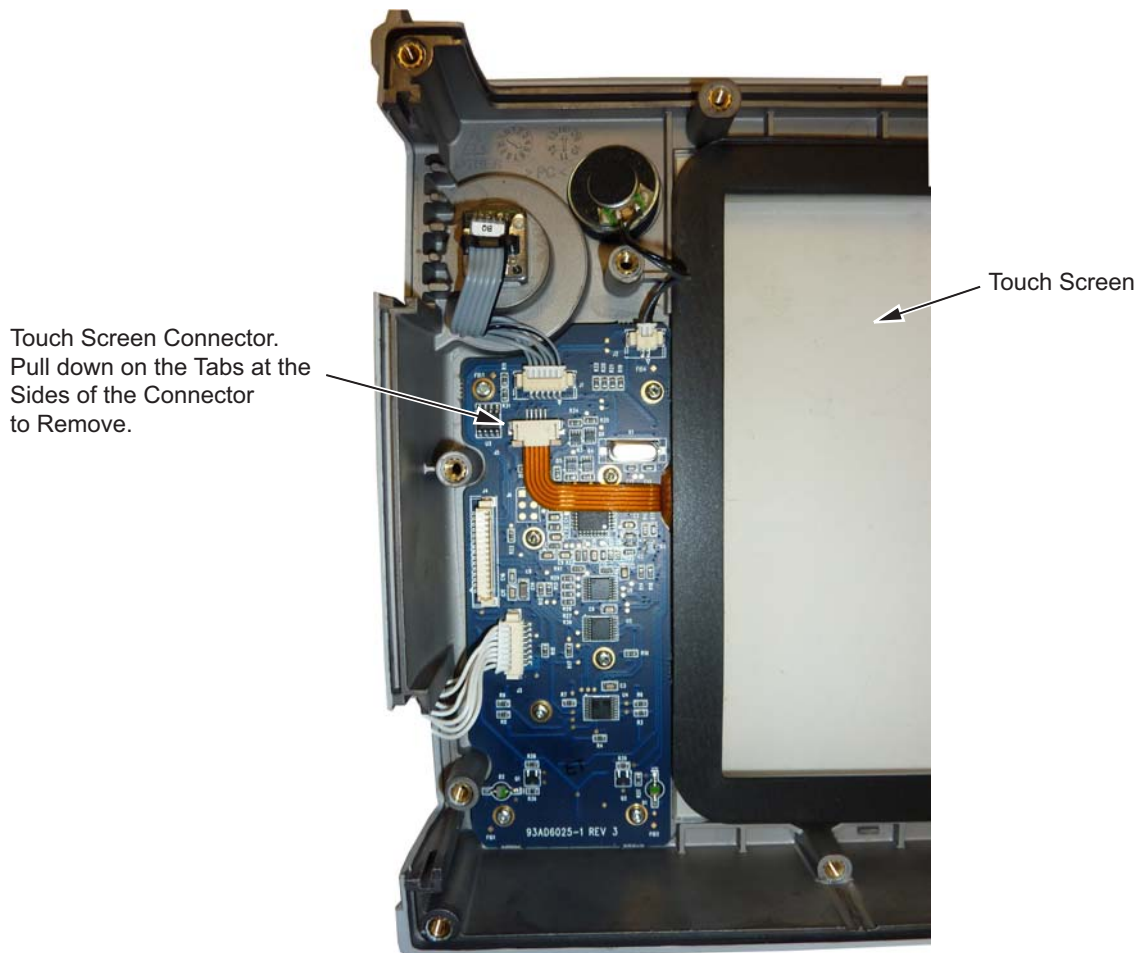

**Figure 6-28.** Replacing the Touch Screen

7. Reverse the above steps to install the replacement Touch Screen.

<b>Note</b>	Firmware version 1.05 and greater was modified to accept touch screen calibration data needed for touch screen part number ND73867. Ensure that firmware version 1.05 or greater is installed. If not, install the latest firmware.
-------------	---

8. Perform a touch screen calibration by pressing the **Shift** key followed by the **0** key, and then following the on-screen calibration instructions.

9. Close the case as described in Section [“Case Reassembly:”](#) on page 6-16.

# Chapter 7 — Troubleshooting

## 7-1 Introduction

This chapter describes the primary troubleshooting operations that can be performed. Perform the troubleshooting suggestions in the order in which they are listed.

Only qualified service personnel should replace internal assemblies. Major sub-assemblies that are shown in the replaceable parts list are typically the items that may be replaced.

Because they are highly fragile, items that must be soldered may not be replaced without special training. Removal of RF shields from PC boards or adjustment of screws on or near the RF shields will detune sensitive RF circuits and will result in degraded instrument performance.

## 7-2 Turn-on Problems

### Instrument Cannot Boot Up

Instrument cannot boot up. No activity occurs when the **On/Off** key is pressed:

1. Battery may have been fully discharged. Use an external charger (Anritsu PN 2000-1374) to charge a completely discharged battery.
2. Battery may be the wrong type. Use only Anritsu approved battery packs. Some non-approved battery packs will fit into the MS2024B, MS2025B, MS2034B, and MS2035B, but they are electrically incompatible and do not charge correctly.
3. External AC to DC power adapter may have failed or be the wrong type. Replace the external power adapter.
4. **On/Off** switch may have damaged. Replace the rubber keypad membrane.
5. Main PCB may have failed. Replace the Main PCB Assembly.

### Instrument Cannot Complete Boot-Up

Instrument begins the boot process, but does not complete boot-up:

1. During the boot-up process, the instrument stops with the message:  

```
Failed to load touch screen calibration data. Please reboot the instrument.
```

  - a. Power the instrument off
  - b. Hold down the **Shift - 4 - 0** keys while pressing the power on button. This forces the instrument to boot up in the boot strap mode.
  - c. In the boot strap mode, the unit prompts you to perform a touch screen calibration. Follow the on-screen directions until the touch screen calibration is complete.
  - d. Power the instrument off and then on again. Observe whether the problem is corrected.
  - e. Once the instrument boots up, verify that the firmware version is 1.50 or greater. If not, load the latest firmware and perform a new touch screen calibration.
2. Firmware update may not have completed. Reload the firmware.
3. The Main PCB may have failed. Replace the Main PCB assembly.

## Instrument Boots with No Display

Instrument produces a ding sound after a while, but with no display:

1. If the display is dim, then check the Brightness setting under the System Menu | System Options.
2. LCD Backlight Inverter PCB may have failed. Replace LCD Backlight Inverter PCB.
3. LCD may have failed. Replace the LCD Display Assembly.
4. The Main PCB may have failed. Replace the Main PCB Assembly.

## Boot-up Self Test Fails

The instrument boot-up self test fails with an error message:

1. Perform a Master Reset (Press **Esc** and **On/Off** keys to turn on the instrument after power has been off).
2. The Main PCB may have failed. Replace the Main PCB Assembly.

## 7-3 Operating Problems

### Battery Pack Charging Problems

1. Refer to [Chapter 5, “Battery Information”](#).

### Touch Screen Problems

Instrument boots correctly, but the touch screen does not react.

1. The touch screen may have lost its calibration data. Press **Shift** then **(0)** zero to enter the touch screen calibration procedure. Follow the direction on the screen.
2. Ensure that instrument firmware version is 1.50 or greater. If not, install the latest firmware version and repeat the touch screen calibration as described in Step 1.
3. Replace the touch screen.

### Vector Network Analyzer Problems

#### Lock Error Message

1. VNA Port may have been damaged, or Main PCB Assembly may have failed.
2. Replace the Main/VNA PCB Assembly for MS202xB or the Main/VNA/DSP PCB Assembly for MS203xB.

#### Measurement Problems

1. Inspect VNA Port 1 and Port 2 connectors for damage.
2. Inspect the Open, Short, Load and cables for damage. Verify their operation on a suitable test instrument.
3. Main PCB Assembly may have failed or may have been damaged. Replace the Main/VNA PCB Assembly for MS202xB or the Main/VNA/DSP PCB Assembly for MS203xB.

## Spectrum Analyzer Problems

### Lock Error Message

1. Spectrum Analyzer PCB Assembly may have failed or may have been damaged. Replace the Spectrum Analyzer Assembly for MS203xB.

### Measurement Problems

1. Inspect the Spectrum Analyzer RF In connector for damage.
2. Refer to the User Guide and Measurement Guide.
3. Update Firmware.
4. Spectrum Analyzer PCB Assembly may have failed or may have been damaged. Replace the Spectrum Analyzer Assembly for MS203xB

## Option 10, VNA Bias Tee Problems

1. Verify that the load current of the attached device does not exceed the current capability of the VNA Master.
2. Perform an operational test. Refer to [Section 4-2 “VNA Mode Bias Tee \(Option 10\) Operational Check” on page 4-2](#).
3. Main PCB Assembly may have failed or may have been damaged. Replace the Main/VNA PCB Assembly for MS202xB or the Main/VNA/DSP PCB Assembly for MS203xB.

## Option 31, GPS Problems

### Unable to Acquire GPS Fix

1. Verify that the GPS Antenna is in direct line-of-sight relationship or is placed outside without any obstructions.
2. If the Anritsu 2000-1528-R GPS Antenna is used, attached the antenna to a large magnetic metal surface such as the roof on a passenger car.
3. Inspect the GPS connector for damage.
4. GPS Receiver Module may have failed. Replace GPS Receiver Module.

**7-4 Other Issues:**

1. Perform a Master Reset.
2. Refer to the User Guide and Measurement Guide.
3. Update firmware.
4. Replace the failed parts or assemblies (for example, the LCD touch screen, keypad, and so forth).



# Appendix A — Test Records

## A-1 Introduction

This appendix provides test records that can be used to record the performance of VNA Master models MS2024B, MS2025B, MS2034B, and MS2035B. Make a copy of the following Test Record pages and document the measured values each time performance verification is performed. Continuing to document this process each performance verification session provides a detailed history of the instrument's performance.

The following test record forms are available:

- [“MS2024B Test Record” on page A-2](#)
- [“MS2025B Test Record” on page A-3](#)
- [“MS2034B Test Record” on page A-4](#)
- [“MS2035B Test Record” on page A-15](#)

Serial Number:	Firmware Revision:	Operator:
Options:		Date:

## A-2 MS2024B Test Record

### VNA Frequency Accuracy

Table A-1. VNA Frequency Accuracy

VNA Output Frequency	Specification	Frequency Counter Reading
2.6 GHz	$\pm 6.5$ kHz	kHz

### VNA Transmission Dynamic Range

\_\_\_\_ Refer to Attached Test Data Report

### VNA Return Loss Measurements Accuracy

Table A-2. VNA Return Loss Measurement Accuracy

Return Loss	Specification	Measured Value
6 dB	$5.05 \text{ dB} \leq x \leq 6.95 \text{ dB}$	dB
20 dB	$18.39 \text{ dB} \leq x \leq 21.61 \text{ dB}$	dB

Serial Number:	Firmware Revision:	Operator:
Options:		Date:

## A-3 MS2025B Test Record

### VNA Frequency Accuracy

Table A-3. VNA Frequency Accuracy

VNA Output Frequency	Specification	Frequency Counter Reading
2.6 GHz	$\pm 6.5$ kHz	kHz

### VNA Transmission Dynamic Range

\_\_\_\_ Refer to Attached Test Data Report

### VNA Return Loss Measurements Accuracy

Table A-4. VNA Return Loss Measurement Accuracy

Return Loss	Specification	Measured Value
6 dB	$5.05 \text{ dB} \leq x \leq 6.95 \text{ dB}$	dB
20 dB	$18.39 \text{ dB} \leq x \leq 21.61 \text{ dB}$	dB

Serial Number:	Firmware Revision:	Operator:
Options:		Date:

## A-4 MS2034B Test Record

### VNA Frequency Accuracy

Table A-5. VNA Frequency Accuracy

VNA Output Frequency	Specification	Frequency Counter Reading
2.6 GHz	$\pm 6.5$ kHz	kHz

### VNA Transmission Dynamic Range

\_\_\_\_ Refer to Attached Test Data Report

### VNA Return Loss Measurements Accuracy

Table A-6. VNA Return Loss Measurement Accuracy

Return Loss	Specification	Measured Value
6 dB	$5.05 \text{ dB} \leq x \leq 6.95 \text{ dB}$	dB
20 dB	$18.39 \text{ dB} \leq x \leq 21.61 \text{ dB}$	dB

### Spectrum Analyzer Residual Spurious Response

Table A-7. Spectrum Analyzer Residual Spurious Response with Preamp Off

Start Freq	Stop Freq	RBW	VBW	Specification	Measured Values
10 MHz	50 MHz	1 kHz	300 Hz	$\leq -90 \text{ dBm}$	dBm
50 MHz	2.0 GHz	3 kHz	10 kHz	$\leq -90 \text{ dBm}$	dBm
2.0 GHz	4.0 GHz	1 kHz	1 kHz	$\leq -90 \text{ dBm}$	dBm

Table A-8. Spectrum Analyzer Residual Spurious Response with Preamp On

Start Freq	Stop Freq	RBW	VBW	Specification	Measured Values
10 MHz	1.0 GHz	1 kHz	300 Hz	$\leq -90 \text{ dBm}$	dBm
1 GHz	4.0 GHz	3 kHz	10 kHz	$\leq -90 \text{ dBm}$	dBm

Serial Number:	Firmware Revision:	Operator:
Options:		Date:

### Spectrum Analyzer Displayed Average Noise Level (DANL)

**Table A-9.** Spectrum Analyzer DANL with Preamp Off

Start Freq	Stop Freq	RBW	VBW	Specification	Measured Values at 100 kHz RBW	Calculated Values for 10 Hz RBW
10 MHz	2.4 GHz	100 kHz	1 kHz	$\leq -131$ dBm	dBm	dBm
2.4 GHz	4.0 GHz	100 kHz	1 kHz	$\leq -127$ dBm	dBm	dBm

**Table A-10.** Spectrum Analyzer DANL with Preamp On

Start Freq	Stop Freq	RBW	VBW	Specification	Measured Values at 100 kHz RBW	Calculated Values for 10 Hz RBW
10 MHz	2.4 GHz	100 kHz	1 kHz	$\leq -147$ dBm	dBm	dBm
2.4 GHz	4.0 GHz	100 kHz	1 kHz	$\leq -144$ dBm	dBm	dBm

### Spectrum Analyzer Frequency Accuracy

**Table A-11.** Spectrum Analyzer Frequency Accuracy

Frequency	Specification	Measured Value	Deviation
1 GHz	$\pm 1.5$ kHz ( $\pm 1.5$ ppm)	GHz	kHz
3.9 GHz	$\pm 5.85$ kHz ( $\pm 1.5$ ppm)	GHz	kHz

### Spectrum Analyzer Frequency Accuracy (Option 31, GPS)

**Table A-12.** Spectrum Analyzer Frequency Accuracy with GPS On

Frequency	Specification	Measured Value	Deviation
3.9 GHz	$\pm 195$ Hz ( $\pm 50$ ppb)	GHz	Hz

Serial Number:	Firmware Revision:	Operator:
Options:		Date:

### Spectrum Analyzer Single Side Band (SSB) Phase Noise

**Table A-13.** Spectrum Analyzer SSB Phase Noise

Offset Frequency	Specification	Measured Value	Calculated Value
10 kHz	$\leq -100$ dBc/Hz	dBc/Hz	dBc/Hz
100 kHz	$\leq -105$ dBc/Hz	dBc/Hz	dBc/Hz
1 MHz	$\leq -115$ dBc/Hz	dBc/Hz	dBc/Hz

### Spectrum Analyzer Spurious Response (Second Harmonic Distortion)

**Table A-14.** Spectrum Analyzer Spurious Response (Second Harmonic Distortion)

Frequency	Specification	Measured Value	2nd Harmonic Level
50.1 MHz		dBm	
100.2 MHz	$\leq -56$ dBc	dBm	dBc

### Spectrum Analyzer Input Related Spurious (IRS) Signals

**Table A-15.** Spectrum Analyzer Input Related Spurious (IRS) Signals

Frequency	Specification	Measured Values	Calculated IRS
2072.5 MHz		dBm	
1222.5 MHz to 2072 MHz	$\leq -60$ dBc	dBm	dBc
2073 MHz to 2922.5 MHz	$\leq -60$ dBc	dBm	dBc
1500 MHz		dBm	
1219 MHz to 1221 MHz	$\leq -52$ dBc	dBm	dBc
1689.5 MHz to 1691.5 MHz	$\leq -52$ dBc	dBm	dBc
2821 MHz to 2823 MHz	$\leq -52$ dBc	dBm	dBc
2421.5 MHz		dBm	
2505 MHz to 2507 MHz	$\leq -39$ dBc	dBm	dBc

Serial Number:	Firmware Revision:	Operator:
Options:		Date:

**Spectrum Analyzer Resolution Bandwidth Accuracy**

**Table A-16.** Spectrum Analyzer Resolution Bandwidth Accuracy

RBW	Span	VBW	Lower Limit	Measured Values	Upper Limit
3 MHz	6 MHz	300 kHz	2.7 MHz	MHz	3.3 MHz
1 MHz	2 MHz	100 kHz	0.9 MHz	MHz	1.1 MHz
300 kHz	600 kHz	30 kHz	270 kHz	kHz	330 kHz
100 kHz	200 kHz	10 kHz	90 kHz	kHz	110 kHz
30 kHz	60 kHz	3 kHz	27 kHz	kHz	33 kHz
10 kHz	20 kHz	1 kHz	9 kHz	kHz	11 kHz
3 kHz	6 kHz	300 Hz	2.7 kHz	kHz	3.3 kHz
1 kHz	2 kHz	100 Hz	0.9 kHz	kHz	1.1 kHz
300 Hz	600 Hz	30 Hz	270 Hz	Hz	330 Hz
100 Hz	200 Hz	10 Hz	90 Hz	Hz	110 Hz
30 Hz	60 Hz	3 Hz	27 Hz	Hz	33 Hz
10 Hz	20 Hz	3 Hz	9 Hz	Hz	11 Hz

Serial Number:	Firmware Revision:	Operator:
Options:		Date:

### Spectrum Analyzer Amplitude Accuracy

**Table A-17.** Spectrum Analyzer 50 MHz Amplitude Accuracy Setup Table

Test Power Level @ 50 MHz	Required Sensor B Reading
0 dBm	dBm
-4 dBm	dBm
-10 dBm	dBm
-14 dBm	dBm
-20 dBm	dBm
-24 dBm	dBm
-30 dBm	dBm
-34 dBm	dBm
-40 dBm	dBm
-44 dBm	dBm
-50 dBm	dBm

**Table A-18.** Spectrum Analyzer 50 MHz Amplitude Accuracy

Test Power	Specification	Reference Level	Atten Level	Measured Value	Deviation
0 dBm	± 1.25 dB	10 dBm	30 dB	dBm	dB
-4 dBm	± 1.25 dB	10 dBm	30 dB	dBm	dB
-10 dBm	± 1.25 dB	0 dBm	20 dB	dBm	dB
-14 dBm	± 1.25 dB	0 dBm	20 dB	dBm	dB
-20 dBm	± 1.25 dB	-10 dBm	10 dB	dBm	dB
-24 dBm	± 1.25 dB	-10 dBm	10 dB	dBm	dB
-30 dBm	± 1.25 dB	-20 dBm	0 dB	dBm	dB
-34 dBm	± 1.25 dB	-20 dBm	0 dB	dBm	dB
-40 dBm	± 1.25 dB	-30 dBm	0 dB	dBm	dB
-44 dBm	± 1.25 dB	-30 dBm	0 dB	dBm	dB
-50 dBm	± 1.25 dB	-40 dBm	0 dB	dBm	dB



Serial Number:	Firmware Revision:	Operator:
Options:		Date:

**Spectrum Analyzer Amplitude Accuracy (continued)**

**Table A-19.** Spectrum Analyzer Amplitude Accuracy Across Frequency Setup Table

Frequency	Required Sensor B reading for -2 dBm @Attenuator output	Required Sensor B reading for -30 dBm @Attenuator output
100 kHz	dBm	dBm
10.1 MHz	dBm	dBm
50 MHz	dBm	dBm
100 MHz	dBm	dBm
500 MHz	dBm	dBm
1000 MHz	dBm	dBm
2000 MHz	dBm	dBm
3000 MHz	dBm	dBm
3999 MHz	dBm	dBm

**Table A-20.** Spectrum Analyzer Amplitude Accuracy Across Frequency – 100 kHz

Test Power dBm	Atten Level dB	Specification dB	Marker 1 Reading dBm	Deviation dB
-30	0	±1.3		
-30	5	±1.3		
-30	10	±1.3		
-30	20	±1.3		
-2	30	±1.3		
-2	40	±1.3		
-2	50	±1.3		
-2	55	±1.3		

Serial Number:	Firmware Revision:	Operator:
Options:		Date:

### Spectrum Analyzer Amplitude Accuracy (continued)

**Table A-21.** Spectrum Analyzer Amplitude Accuracy Across Frequency – 10.1 MHz

Test Power dBm	Atten Level dB	Specification dB	Marker 1 Reading dBm	Deviation dB
-30	0	±1.3		
-30	5	±1.3		
-30	10	±1.3		
-30	20	±1.3		
-2	30	±1.3		
-2	40	±1.3		
-2	50	±1.3		
-2	55	±1.3		

**Table A-22.** Spectrum Analyzer Amplitude Accuracy Across Frequency – 50 MHz

Test Power dBm	Atten Level dB	Specification dB	Marker 1 Reading dBm	Deviation dB
-30	0	±1.3		
-30	5	±1.3		
-30	10	±1.3		
-30	20	±1.3		
-2	30	±1.3		
-2	40	±1.3		
-2	50	±1.3		
-2	55	±1.3		

Serial Number:	Firmware Revision:	Operator:
Options:		Date:

**Spectrum Analyzer Amplitude Accuracy (continued)**

**Table A-23.** Spectrum Analyzer Amplitude Accuracy Across Frequency – 100 MHz

Test Power dBm	Atten Level dB	Specification dB	Marker 1 Reading dBm	Deviation dB
-30	0	±1.3		
-30	5	±1.3		
-30	10	±1.3		
-30	20	±1.3		
-2	30	±1.3		
-2	40	±1.3		
-2	50	±1.3		
-2	55	±1.3		

**Table A-24.** Spectrum Analyzer Amplitude Accuracy Across Frequency – 500 MHz

Test Power dBm	Atten Level dB	Specification dB	Marker 1 Reading dBm	Deviation dB
-30	0	±1.3		
-30	5	±1.3		
-30	10	±1.3		
-30	20	±1.3		
-2	30	±1.3		
-2	40	±1.3		
-2	50	±1.3		
-2	55	±1.3		

Serial Number:	Firmware Revision:	Operator:
Options:		Date:

### Spectrum Analyzer Amplitude Accuracy (continued)

**Table A-25.** Spectrum Analyzer Amplitude Accuracy Across Frequency – 1000 MHz

Test Power dBm	Atten Level dB	Specification dB	Marker 1 Reading dBm	Deviation dB
-30	0	±1.3		
-30	5	±1.3		
-30	10	±1.3		
-30	20	±1.3		
-2	30	±1.3		
-2	40	±1.3		
-2	50	±1.3		
-2	55	±1.3		

**Table A-26.** Spectrum Analyzer Amplitude Accuracy Across Frequency – 2000 MHz

Test Power dBm	Atten Level dB	Specification dB	Marker 1 Reading dBm	Deviation dB
-30	0	±1.3		
-30	5	±1.3		
-30	10	±1.3		
-30	20	±1.3		
-2	30	±1.3		
-2	40	±1.3		
-2	50	±1.3		
-2	55	±1.3		

Serial Number:	Firmware Revision:	Operator:
Options:		Date:

**Spectrum Analyzer Amplitude Accuracy (continued)**

**Table A-27.** Spectrum Analyzer Amplitude Accuracy Across Frequency – 3000 MHz

Test Power dBm	Atten Level dB	Specification dB	Marker 1 Reading dBm	Deviation dB
-30	0	±1.3		
-30	5	±1.3		
-30	10	±1.3		
-30	20	±1.3		
-2	30	±1.3		
-2	40	±1.3		
-2	50	±1.3		
-2	55	±1.3		

**Table A-28.** Spectrum Analyzer Amplitude Accuracy Across Frequency – 3999 MHz

Test Power dBm	Atten Level dB	Specification dB	Marker 1 Reading dBm	Deviation dB
-30	0	±1.3		
-30	5	±1.3		
-30	10	±1.3		
-30	20	±1.3		
-2	30	±1.3		
-2	40	±1.3		
-2	50	±1.3		
-2	55	±1.3		

Serial Number:	Firmware Revision:	Operator:
Options:		Date:

### Third Order Intercept

**Table A-29.** Spectrum Analyzer Third Order Intercept

Third Order Intercept at Center Frequency	Measured Value	Specification
800.151 MHz	dBm	
799.851 MHz	dBm	
Calculated TOI at 800 MHz	dBm	$\geq +16$ dBm
2400.151 MHz	dBm	
2399.851 MHz	dBm	
Calculated TOI at 2400 MHz	dBm	$\geq +20$ dBm

Serial Number:	Firmware Revision:	Operator:
Options:		Date:

## A-5 MS2035B Test Record

### VNA Frequency Accuracy

Table A-30. VNA Frequency Accuracy

VNA Output Frequency	Specification	Frequency Counter Reading
2.6 GHz	$\pm 6.5$ kHz	kHz

### VNA Transmission Dynamic Range

\_\_\_\_\_ Refer to Attached Test Data Report

### VNA Return Loss Measurements Accuracy

Table A-31. VNA Return Loss Measurement Accuracy

Return Loss	Specification	Measured Value
6 dB	$5.05 \text{ dB} \leq x \leq 6.95 \text{ dB}$	dB
20 dB	$18.39 \text{ dB} \leq x \leq 21.61 \text{ dB}$	dB

Serial Number:	Firmware Revision:	Operator:
Options:		Date:

### Spectrum Analyzer Residual Spurious Response

**Table A-32.** Spectrum Analyzer Residual Spurious Response with Preamp Off

Start Freq	Stop Freq	RBW	VBW	Specification	Measured Values
10 MHz	50 MHz	1 kHz	300 Hz	$\leq -90$ dBm	dBm
50 MHz	2.0 GHz	3 kHz	10 kHz	$\leq -90$ dBm	dBm
2.0 GHz	4.0 GHz	1 kHz	1 kHz	$\leq -90$ dBm	dBm
4.0 GHz	5.0 GHz	1 kHz	3 kHz	$\leq -90$ dBm	dBm
5.0 GHz	5.2 GHz	1 kHz	1 kHz	$\leq -90$ dBm	dBm
5.2 GHz	5.7 GHz	300 Hz	3 kHz	$\leq -90$ dBm	dBm
5.7 GHz	5.9 GHz	300 Hz	3 kHz	$\leq -90$ dBm	dBm
5.9 GHz	6.0 GHz	1 kHz	100 Hz	$\leq -90$ dBm	dBm

**Table A-33.** Spectrum Analyzer Residual Spurious Response with Preamp On

Start Freq	Stop Freq	RBW	VBW	Specification	Measured Values
10 MHz	1.0 GHz	1 kHz	300 Hz	$\leq -90$ dBm	dBm
1.0 GHz	4.0 GHz	3 kHz	10 kHz	$\leq -90$ dBm	dBm
4.0 GHz	6.0 GHz	30 kHz	3 kHz	$\leq -90$ dBm	dBm



Serial Number:	Firmware Revision:	Operator:
Options:		Date:

### Spectrum Analyzer Displayed Average Noise Level (DANL)

**Table A-34.** Spectrum Analyzer DANL with Preamp Off

Start Freq	Stop Freq	RBW	VBW	Specification	Measured Values at 100 kHz RBW	Calculated Values for 10 Hz RBW
10 MHz	2.4 GHz	100 kHz	1 kHz	$\leq -131$ dBm	dBm	dBm
2.4 GHz	4.0 GHz	100 kHz	1 kHz	$\leq -127$ dBm	dBm	dBm
4.0 GHz	5.0 GHz	100 kHz	1 kHz	$\leq -124$ dBm	dBm	dBm
5.0 GHz	6.0 GHz	100 kHz	1 kHz	$\leq -116$ dBm	dBm	dBm

**Table A-35.** Spectrum Analyzer DANL with Preamp On

Start Freq	Stop Freq	RBW	VBW	Specification	Measured Values at 100 kHz RBW	Calculated Values for 10 Hz RBW
10 MHz	2.4 GHz	100 kHz	1 kHz	$\leq -147$ dBm	dBm	dBm
2.4 GHz	4.0 GHz	100 kHz	1 kHz	$\leq -144$ dBm	dBm	dBm
4.0 GHz	5.0 GHz	100 kHz	1 kHz	$\leq -140$ dBm	dBm	dBm
5.0 GHz	6.0 GHz	100 kHz	1 kHz	$\leq -133$ dBm	dBm	dBm

Serial Number:	Firmware Revision:	Operator:
Options:		Date:

### Spectrum Analyzer Frequency Accuracy

**Table A-36.** Spectrum Analyzer Frequency Accuracy

Frequency	Specification	Measured Value	Deviation
1 GHz	$\pm 1.5$ kHz ( $\pm 1.5$ ppm)	GHz	kHz
3.9 GHz	$\pm 5.85$ kHz ( $\pm 1.5$ ppm)	GHz	kHz
5.9 GHz	$\pm 8.85$ kHz ( $\pm 1.5$ ppm)	GHz	kHz

### Spectrum Analyzer Frequency Accuracy (Option 31, GPS)

**Table A-37.** Spectrum Analyzer Frequency Accuracy with GPS On

Frequency	Specification	Measured Value	Deviation
5.9 GHz	$\pm 295$ Hz ( $\pm 50$ ppb)	GHz	Hz

### Single Side Band (SSB) Phase Noise

**Table A-38.** Spectrum Analyzer SSB Phase Noise

Offset Frequency	Specification	Measured Value	Calculated Value
10 kHz	$\leq -100$ dBc/Hz	dBc/Hz	dBc/Hz
100 kHz	$\leq -105$ dBc/Hz	dBc/Hz	dBc/Hz
1 MHz	$\leq -115$ dBc/Hz	dBc/Hz	dBc/Hz

Serial Number:	Firmware Revision:	Operator:
Options:		Date:

**Spectrum Analyzer Spurious Response (Second Harmonic Distortion)**

**Table A-39.** Spectrum Analyzer Spurious Response (Second Harmonic Distortion)

Frequency	Specification	Measured Value	2nd Harmonic Level
50.1 MHz		dBm	
100.2 MHz	≤ -56 dBc	dBm	dBc

**Spectrum Analyzer Input Related Spurious (IRS) Signals**

**Table A-40.** Spectrum Analyzer Input Related Spurious (IRS) Signals

Frequency	Specification	Measured Values	Calculated IRS
2072.5 MHz		dBm	
1222.5 MHz to 2072 MHz	≤ -60 dBc	dBm	dBc
2073 MHz to 2922.5 MHz	≤ -60 dBc	dBm	dBc
1500 MHz		dBm	
1219 MHz to 1221 MHz	≤ -52 dBc	dBm	dBc
1689.5 MHz to 1691.5 MHz	≤ -52 dBc	dBm	dBc
2821 MHz to 2823 MHz	≤ -52 dBc	dBm	dBc
2421.5 MHz		dBm	
2505 MHz to 2507 MHz	≤ -39 dBc	dBm	dBc

Serial Number:	Firmware Revision:	Operator:
Options:		Date:

### Spectrum Analyzer Resolution Bandwidth Accuracy

**Table A-41.** Spectrum Analyzer Resolution Bandwidth Accuracy

RBW	Span	VBW	Lower Limit	Measured Values	Upper Limit
3 MHz	6 MHz	300 kHz	2.7 MHz	MHz	3.3 MHz
1 MHz	2 MHz	100 kHz	0.9 MHz	MHz	1.1 MHz
300 kHz	600 kHz	30 kHz	270 kHz	kHz	330 kHz
100 kHz	200 kHz	10 kHz	90 kHz	kHz	110 kHz
30 kHz	60 kHz	3 kHz	27 kHz	kHz	33 kHz
10 kHz	20 kHz	1 kHz	9 kHz	kHz	11 kHz
3 kHz	6 kHz	300 Hz	2.7 kHz	kHz	3.3 kHz
1 kHz	2 kHz	100 Hz	0.9 kHz	kHz	1.1 kHz
300 Hz	600 Hz	30 Hz	270 Hz	Hz	330 Hz
100 Hz	200 Hz	10 Hz	90 Hz	Hz	110 Hz
30 Hz	60 Hz	3 Hz	27 Hz	Hz	33 Hz
10 Hz	20 Hz	3 Hz	9 Hz	Hz	11 Hz

Serial Number:	Firmware Revision:	Operator:
Options:		Date:

### Spectrum Analyzer Amplitude Accuracy

**Table A-42.** Spectrum Analyzer 50 MHz Amplitude Accuracy Setup Table

Test Power Level at 50 MHz	Required Sensor B Reading
0 dBm	dBm
-4 dBm	dBm
-10 dBm	dBm
-14 dBm	dBm
-20 dBm	dBm
-24 dBm	dBm
-30 dBm	dBm
-34 dBm	dBm
-40 dBm	dBm
-44 dBm	dBm
-50 dBm	dBm

**Table A-43.** Spectrum Analyzer 50 MHz Amplitude Accuracy

Test Power	Specification	Reference Level	Atten Level	Measured Value	Deviation
0 dBm	±1.3 dB	10 dBm	30 dB	dBm	dB
-4 dBm	±1.3 dB	10 dBm	30 dB	dBm	dB
-10 dBm	±1.3 dB	0 dBm	20 dB	dBm	dB
-14 dBm	±1.3 dB	0 dBm	20 dB	dBm	dB
-20 dBm	±1.3 dB	-10 dBm	10 dB	dBm	dB
-24 dBm	±1.3 dB	-10 dBm	10 dB	dBm	dB
-30 dBm	±1.3 dB	-20 dBm	0 dB	dBm	dB
-34 dBm	±1.3 dB	-20 dBm	0 dB	dBm	dB
-40 dBm	±1.3 dB	-30 dBm	0 dB	dBm	dB
-44 dBm	±1.3 dB	-30 dBm	0 dB	dBm	dB
-50 dBm	±1.3 dB	-40 dBm	0 dB	dBm	dB

Serial Number:	Firmware Revision:	Operator:
Options:		Date:

### Spectrum Analyzer Amplitude Accuracy (continued)

**Table A-44.** Spectrum Analyzer Amplitude Accuracy Across Frequency Setup Table

Frequency	Required Sensor B reading for –2 dBm at Attenuator output	Required Sensor B reading for –30 dBm at Attenuator output
100 kHz	dBm	dBm
10.1 MHz	dBm	dBm
50 MHz	dBm	dBm
100 MHz	dBm	dBm
500 MHz	dBm	dBm
1000 MHz	dBm	dBm
2000 MHz	dBm	dBm
3000 MHz	dBm	dBm
4000 MHz	dBm	dBm
5000 MHz	dBm	dBm
5999 MHz	dBm	dBm

**Table A-45.** Spectrum Analyzer Amplitude Accuracy Across Frequency – 100 kHz

Test Power dBm	Atten Level dB	Specification dB	Marker 1 Reading dBm	Deviation dB
–30	0	±1.3		
–30	5	±1.3		
–30	10	±1.3		
–30	20	±1.3		
–2	30	±1.3		
–2	40	±1.3		
–2	50	±1.3		
–2	55	±1.3		

Serial Number:	Firmware Revision:	Operator:
Options:		Date:

**Spectrum Analyzer Amplitude Accuracy (continued)**

**Table A-46.** Spectrum Analyzer Amplitude Accuracy Across Frequency – 10.1 MHz

Test Power dBm	Atten Level dB	Specification dB	Marker 1 Reading dBm	Deviation dB
-30	0	±1.3		
-30	5	±1.3		
-30	10	±1.3		
-30	20	±1.3		
-2	30	±1.3		
-2	40	±1.3		
-2	50	±1.3		
-2	55	±1.3		

**Table A-47.** Spectrum Analyzer Amplitude Accuracy Across Frequency – 50 MHz

Test Power dBm	Atten Level dB	Specification dB	Marker 1 Reading dBm	Deviation dB
-30	0	±1.3		
-30	5	±1.3		
-30	10	±1.3		
-30	20	±1.3		
-2	30	±1.3		
-2	40	±1.3		
-2	50	±1.3		
-2	55	±1.3		

Serial Number:	Firmware Revision:	Operator:
Options:		Date:

### Spectrum Analyzer Amplitude Accuracy (continued)

**Table A-48.** Spectrum Analyzer Amplitude Accuracy Across Frequency – 100 MHz

Test Power dBm	Atten Level dB	Specification dB	Marker 1 Reading dBm	Deviation dB
-30	0	±1.3		
-30	5	±1.3		
-30	10	±1.3		
-30	20	±1.3		
-2	30	±1.3		
-2	40	±1.3		
-2	50	±1.3		
-2	55	±1.3		

**Table A-49.** Spectrum Analyzer Amplitude Accuracy Across Frequency – 500 MHz

Test Power dBm	Atten Level dB	Specification dB	Marker 1 Reading dBm	Deviation dB
-30	0	±1.3		
-30	5	±1.3		
-30	10	±1.3		
-30	20	±1.3		
-2	30	±1.3		
-2	40	±1.3		
-2	50	±1.3		
-2	55	±1.3		



Serial Number:	Firmware Revision:	Operator:
Options:		Date:

**Spectrum Analyzer Amplitude Accuracy (continued)**

**Table A-50.** Spectrum Analyzer Amplitude Accuracy Across Frequency – 1000 MHz

Test Power dBm	Atten Level dB	Specification dB	Marker 1 Reading dBm	Deviation dB
-30	0	±1.3		
-30	5	±1.3		
-30	10	±1.3		
-30	20	±1.3		
-2	30	±1.3		
-2	40	±1.3		
-2	50	±1.3		
-2	55	±1.3		

**Table A-51.** Spectrum Analyzer Amplitude Accuracy Across Frequency – 2000 MHz

Test Power dBm	Atten Level dB	Specification dB	Marker 1 Reading dBm	Deviation dB
-30	0	±1.3		
-30	5	±1.3		
-30	10	±1.3		
-30	20	±1.3		
-2	30	±1.3		
-2	40	±1.3		
-2	50	±1.3		
-2	55	±1.3		

Serial Number:	Firmware Revision:	Operator:
Options:		Date:

### Spectrum Analyzer Amplitude Accuracy (continued)

**Table A-52.** Spectrum Analyzer Amplitude Accuracy Across Frequency – 3000 MHz

Test Power dBm	Atten Level dB	Specification dB	Marker 1 Reading dBm	Deviation dB
-30	0	±1.3		
-30	5	±1.3		
-30	10	±1.3		
-30	20	±1.3		
-2	30	±1.3		
-2	40	±1.3		
-2	50	±1.3		
-2	55	±1.3		

**Table A-53.** Spectrum Analyzer Amplitude Accuracy Across Frequency – 4000 MHz

Test Power dBm	Atten Level dB	Specification dB	Marker 1 Reading dBm	Deviation dB
-30	0	±1.3		
-30	5	±1.3		
-30	10	±1.3		
-30	20	±1.3		
-2	30	±1.3		
-2	40	±1.3		
-2	50	±1.3		
-2	55	±1.3		

Serial Number:	Firmware Revision:	Operator:
Options:		Date:

**Spectrum Analyzer Amplitude Accuracy (continued)**

**Table A-54.** Spectrum Analyzer Amplitude Accuracy Across Frequency – 5000 MHz

Test Power dBm	Atten Level dB	Specification dB	Marker 1 Reading dBm	Deviation dB
-30	0	±1.3		
-30	5	±1.3		
-30	10	±1.3		
-30	20	±1.3		
-2	30	±1.3		
-2	40	±1.3		
-2	50	±1.3		
-2	55	±1.3		

**Table A-55.** Spectrum Analyzer Amplitude Accuracy Across Frequency – 5999 MHz

Test Power dBm	Atten Level dB	Specification dB	Marker 1 Reading dBm	Deviation dB
-30	0	±1.3		
-30	5	±1.3		
-30	10	±1.3		
-30	20	±1.3		
-2	30	±1.3		
-2	40	±1.3		
-2	50	±1.3		
-2	55	±1.3		

Serial Number:	Firmware Revision:	Operator:
Options:		Date:

### Third Order Intercept

**Table A-56.** Spectrum Analyzer Third Order Intercept

Third Order Intercept at Center Frequency	Measured Value	Specification
800.151 MHz	dBm	
799.851 MHz	dBm	
Calculated TOI at 800 MHz	dBm	$\geq +16$ dBm
2400.151 MHz	dBm	
2399.851 MHz	dBm	
Calculated TOI at 2400 MHz	dBm	$\geq +20$ dBm

# Appendix B — Test Fixture Schematics

## B-1 Introduction

The following schematics are provided for those wishing to build their own test fixtures for the Option 10 verification test. The part numbers that are referenced in the schematics are Anritsu part numbers.

## B-2 T2904 Test Fixture Schematic

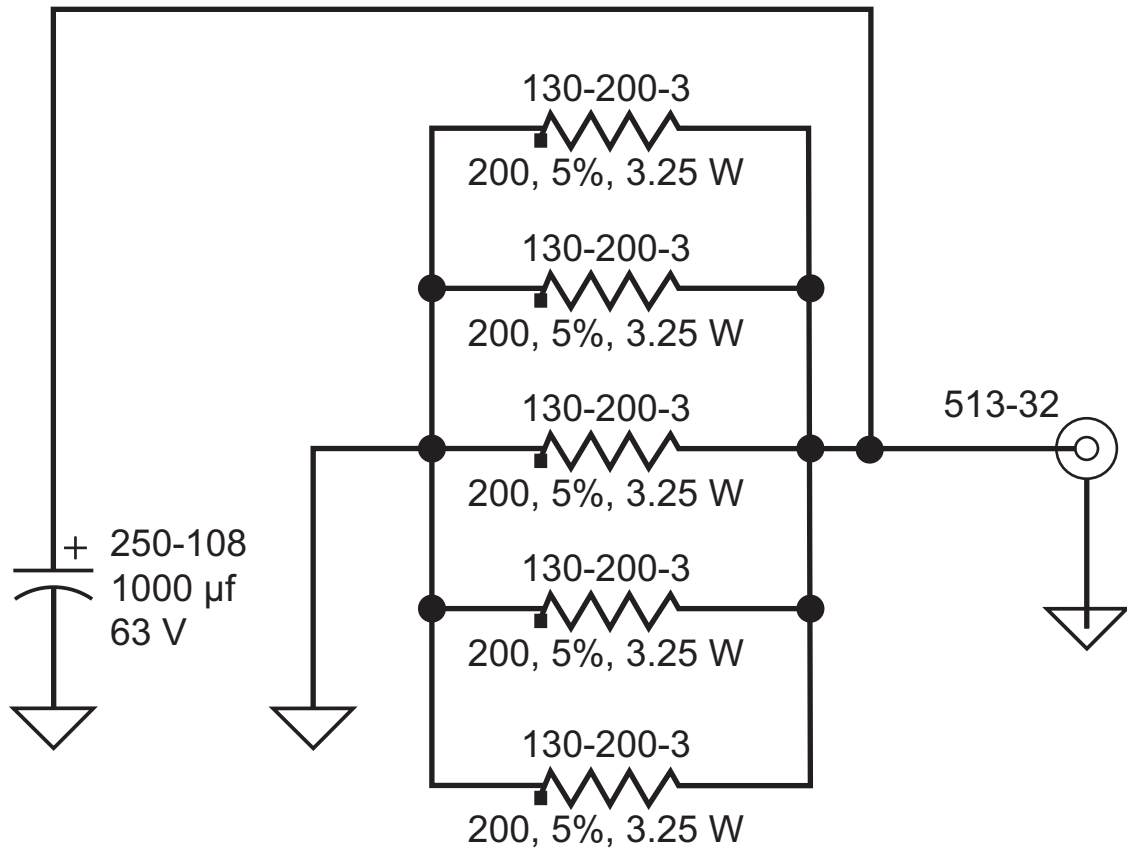

Figure B-1. T2904 Test Fixture Schematic

### B-3 T3377 Test Fixture Schematic

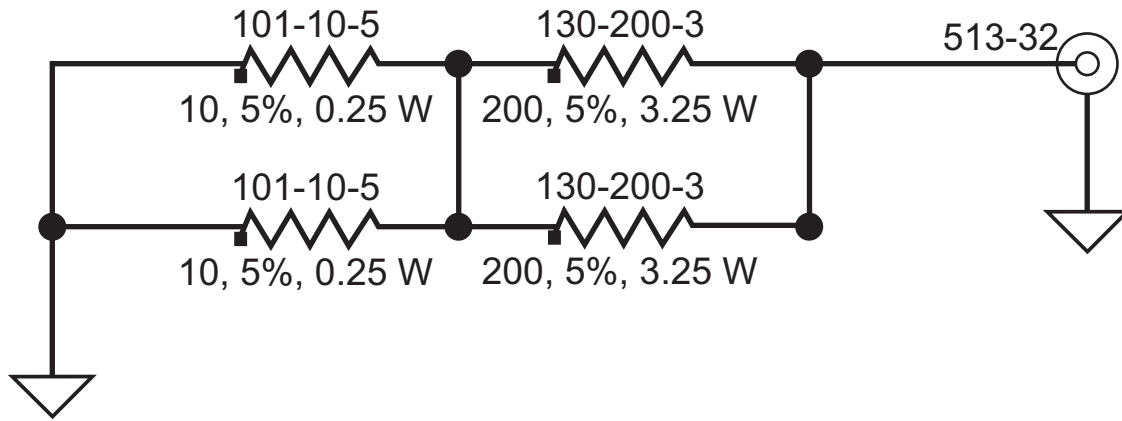

Figure B-2. T3377 Test Fixture Schematic

### B-4 T3536 Test Fixture Schematic

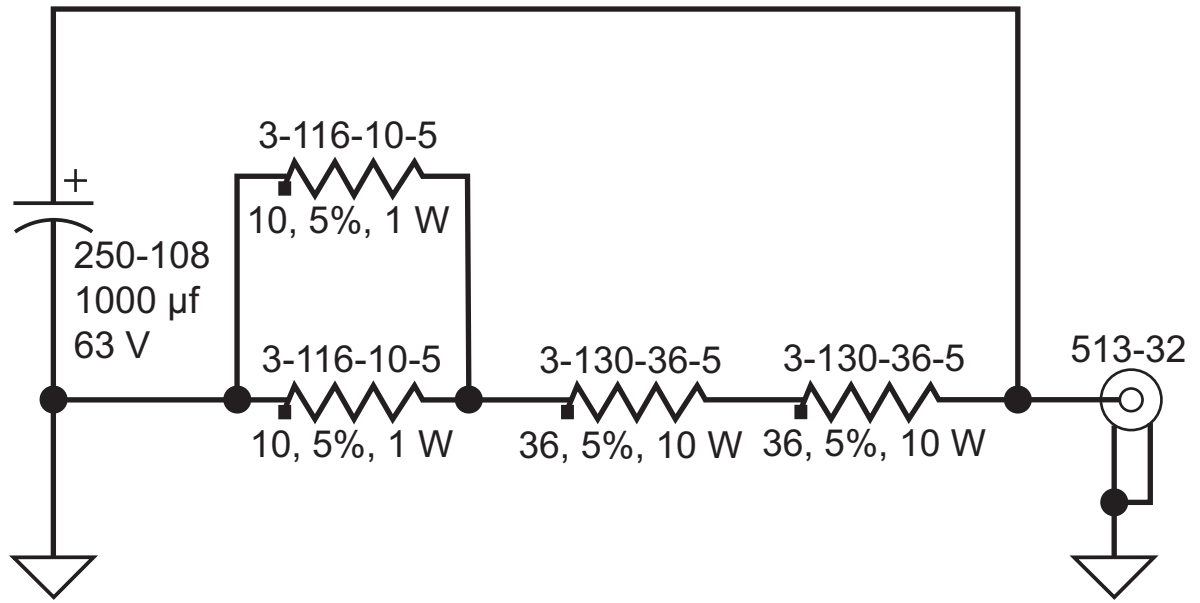

Figure B-3. T3536 Test Fixture Schematic





# Index

- A**
- accessories, standard ..... 1-2
  - amplitude accuracy test, SPA ..... 3-20
- B**
- battery
    - completely discharged ..... 7-1
    - pack information ..... 5-4
    - pack removal ..... 5-2
  - battery charging problems ..... 7-2
  - Bias Tee problems ..... 7-3
  - Bias Tee test, options ..... 4-2
  - boot up problems ..... 7-1
- C**
- case, opening ..... 6-14
  - cautions
    - equipment warm-up time ..... 2-1, 3-1, 4-1
    - ESD, electrostatic discharge ..... 6-14
    - Ethernet PCB removal ..... 6-26
    - RF shields ..... 6-13
  - completely discharged battery ..... 7-1
- D**
- DANL test, SPA ..... 3-4
  - discharged battery ..... 7-1
- F**
- files, saving ..... 6-13
  - frequency accuracy test
    - options, SPA GPS ..... 4-6
    - SPA ..... 3-6
    - VNA ..... 2-1
  - frequency ranges of instruments ..... 1-2
- G**
- GPS problems ..... 7-3
  - GPS test, options ..... 4-4
- I**
- instrument cannot boot up ..... 7-1
  - instrument cannot complete boot-up ..... 7-1
  - instrument frequency ranges ..... 1-2
  - instrument terminology ..... 1-1
  - IRS signals test, SPA ..... 3-13
- L**
- list of recommended test equipment ..... 1-4
  - list of replaceable parts ..... 1-7
  - lock error message, SPA ..... 7-3
  - lock error message, VNA ..... 7-2
- N**
- no display problems ..... 7-2
- O**
- opening the case ..... 6-14
  - operating problems, troubleshooting ..... 7-2
  - options tests
    - Bias Tee ..... 4-2
    - frequency accuracy, SPA GPS ..... 4-6
    - GPS ..... 4-4
- P**
- parts, replaceable ..... 1-7
- R**
- recommended test equipment ..... 1-4
  - records, test results ..... A-1
  - remove - replace
    - list of instructions ..... 6-2, 6-13
    - backlight PCB ..... 6-35
    - battery ..... 5-2
    - closing the case ..... 6-16
    - display (LCD) ..... 6-32
    - Ethernet LAN PCB ..... 6-26
    - fan assembly ..... 6-30
    - GPS module ..... 6-24
    - keypad and PCB ..... 6-36
    - LAN, Ethernet PCB ..... 6-26
    - LCD assembly ..... 6-32
    - LCD backlight PCB ..... 6-35
    - Main/VNA PCB assembly ..... 6-28
    - Main/VNA/DSP PCB assembly ..... 6-29
    - opening the case ..... 6-14
    - PCB assembly ..... 6-16
    - PCB installation ..... 6-18
    - SPA PCB installation ..... 6-19
    - touch screen ..... 6-37
  - replaceable parts ..... 1-7
  - residual spurious response test, SPA ..... 3-2
  - resolution bandwidth accuracy test, SPA ..... 3-17
  - return loss test, VNA ..... 2-3
- S**
- Safety Symbols
    - For Safety ..... Safety-2
    - In Manuals ..... Safety-1
    - On Equipment ..... Safety-1
  - saving files ..... 6-13
  - schematics, test fixtures ..... B-1
  - self test fails problems ..... 7-2
  - SPA measurement problems ..... 7-3

SPA tests

- amplitude accuracy ..... 3-20
- DANL ..... 3-4
- frequency accuracy ..... 3-6
- IRS signals ..... 3-13
- residual spurious response ..... 3-2
- resolution bandwidth accuracy ..... 3-17
- spurious response ..... 3-10
- SSB phase noise ..... 3-8
- third order intercept ..... 3-30
- spectrum analyzer problems ..... 7-3
- spurious response test, SPA ..... 3-10
- SSB phase noise test, SPA ..... 3-8
- standard accessories ..... 1-2

**T**

- T2904 test fixture ..... B-1
- T3377 test fixture ..... B-2
- T3536 test fixture ..... B-3
- terms to describe instruments ..... 1-1
- test equipment, recommended ..... 1-4
- test fixture schematics
  - T2904 ..... B-1
  - T3377 ..... B-2
  - T3536 ..... B-3
- test records ..... A-1
- third order intercept test, SPA ..... 3-30
- touch screen problems ..... 7-2
- transmission dynamic range test record
  - MS2024B ..... A-2
  - MS2025B ..... A-3
  - MS2034B ..... A-4
  - MS2035B ..... A-15

- transmission dynamic range test, VNA ..... 2-2
- troubleshooting
  - battery charging ..... 7-2
  - Bias Tee, VNA ..... 7-3
  - boot up ..... 7-1
  - GPS ..... 7-3
  - no display ..... 7-2
  - operating problems ..... 7-2
  - self test fails ..... 7-2
  - SPA lock error message ..... 7-3
  - SPA measurements ..... 7-3
  - spectrum analyzer ..... 7-3
  - touch screen ..... 7-2
  - turn on problems ..... 7-1
  - VNA lock error message ..... 7-2
  - VNA measurements ..... 7-2
  - VNA problems ..... 7-2
- turn on problems, troubleshooting ..... 7-1

**V**

- VNA frequency accuracy test record
  - MS2024B ..... A-2
  - MS2025B ..... A-3
  - MS2034B ..... A-4
  - MS2035B ..... A-15
- VNA measurement problems ..... 7-2
- VNA tests
  - frequency accuracy ..... 2-1
  - return loss ..... 2-3
  - transmission dynamic range ..... 2-2



# Anritsu

---



Anritsu prints on recycled paper with vegetable soybean oil ink.

Anritsu Company  
490 Jarvis Drive  
Morgan Hill, CA 95037-2809  
USA  
<http://www.anritsu.com>